

Service
Service
Service



Service Manual

TABLE OF CONTENTS

	Chapter
Technical Specification, PCBs Location.....	1
Safety Instruction	2
Instruction for Use.....	3
Mechanical and Dismantling Instructions.....	4
Service Modes, Troubleshooting.....	5
Overall Block Diagram, Wiring Diagram.....	6
Electrical Diagram.....	7
Exploded View Diagram & Service Part List.....	8
Revision List.....	9

© Copyright 2011 Philips Consumer Electronics B.V. Eindhoven, The Netherlands
All rights reserved. No part of this publication may be reproduced, stored in a retrieval system or transmitted, in any form or by any means, electronic, mechanical, photocopying, or otherwise without the prior permission of Philips.

Published BG AVM Printed in The Netherlands Subject to modification

3141 785 36930

Version 1.0



PHILIPS

11 Specifications

Specifications are subject to change without notice

Playable media

- BD-Video
- DVD-Video, DVD+R/+RW, DVD-R/-RW, DVD+R/-R DL (Dual Layer)
- VCD/SVCD
- Audio CD, CD-R/CD-RW, MP3 media, WMA media, JPEG files
- DivX (Ultra)/DivX Plus HD media, MKV media
- USB storage device

File format

- Video: .avi, .divx, .mp4, .mkv
- Audio: .mp3, .wma, .wav
- Picture: .jpg, .gif, .png

Video

- Signal system: PAL / NTSC
- Composite video output: 1 Vp-p (75 ohm)
- HDMI output 480p, 576p, 720p, 1080i, 1080p, 1080p24

Audio

- 2 Channel analog output
 - Audio Front L&R : 2 Vrms (> 1 kohm)
- Digital output: 0.5 Vp-p (75 ohm)
 - Coaxial
- HDMI output
- Sampling frequency:
 - MP3: 32 kHz 44.1 kHz 48 kHz
 - WMA: 44.1 kHz 48 kHz
- Constant bit rate:
 - MP3: 112 kbps - 320 kbps
 - WMA: 48 kbps - 192 kbps

USB

- Compatibility: Hi-Speed USB (2.0)
- Class support: USB Mass Storage Class (UMS)
- File system: FAT16, FAT32
- Support HDD (a portable hard drive disc): an external power source may be needed.

Main unit

- Power supply rating: AC 110-120V $\sqrt{}$ -50Hz 60Hz
- Power consumption: 18 W
- Power consumption in standby mode: < 0.5 W
- Dimensions (w x h x d): 435 X 41 X 195.5 (mm)
- Net Weight: 1.4 kg

Accessories supplied

- Remote control and batteries
- User manual

Optional accessory

- A wireless Philips USB adapter(named WUB1110, sold separately)
- Multimedia connections: Wi-Fi 802.11b/g/n
- Connectivity: Rear connection (USB),
- Ambient temperature: 5 deg C to 40 deg C.
- Dongle dimensions (W x H x D): 28.4 x 82 x 13.4 mm

Laser Specification

- Laser Type (Diode): AlGaInN (BD), AlGaInP (DVD/CD)
- Wave length: 405+7nm/-7nm (BD), 655+10nm/-10nm (DVD), 790+10/-20nm (CD)
- Output power: 1mW (BD), 0.26mW (DVD), 0.3mW (CD)

1.1 PCBs Location

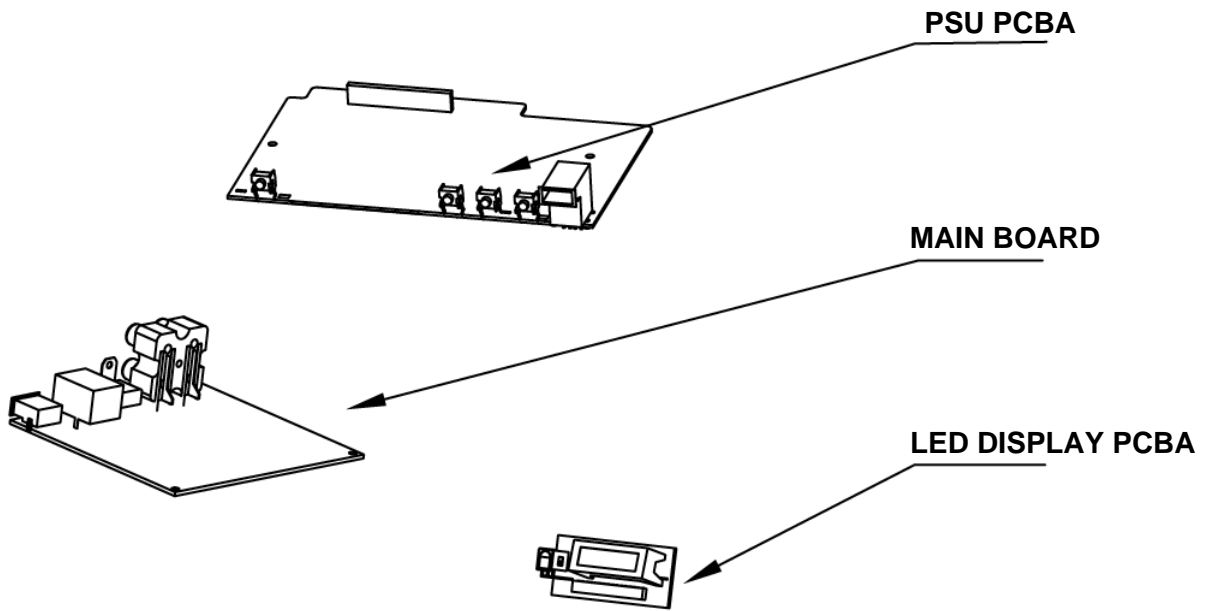

VERSION VARIATIONS

Type/Versions:		BDP5406					
Service policy		F7					
Board in used:							
MAIN BOARD		M					
PSU PCBA		M					
LED DISPLAY PCBA		M					

*TIPS: C -- Component Lever Repair.
 M -- Module Lever Repair
 X -- OCX

Software check and upgrade

Preparation to upgrade software

- 1) Start the CD burning software & create a folder named "UPGAL
- 2) Then copy the Bin file (BDP3XXXXX-XXX-XXXXXX.bin) into it,
- 3) Burn the data onto the blank CD.

A. Procedure for software upgrade

A) Upgrade software via Disc

- 1) Power on the set and insert the prepared Upgrade CDR.
- 2) The set will start reading disc & response with the following display TV screen:
Now searching for upgrade software!
Please wait...!
- 3) Then screen will display :
software upgrades for this player has been found! Do you want to upgrade?

Cancel Start
- 4) Press Right cursor button to choose "Start", then press <OK>;
- 5) The software will upgrade and screen will display as below:
Upgrade is ongoing, Please wait...
Please do not unplug or switch off the device.
- 6) Restart the set.

B) Update software via USB Flash Drive:

- 1) Go to www.philips.com/support to check if the latest software version is available for this player.
- 2) Download the software onto a USB flash drive's root DIR named "UPGAL
- 3) Insert the USB flash drive to the USB jack of the rear panel.
- 4) In the Home menu, select <Setup>-<Advanced>-<Software update>-<USB>.
- 5) Then press OK
- 6) you'll see now searching for new software, please wait.....
- 7) Waiting, you'll see "software for this player has been found"
- 8) Then select "Start" and press "OK"
- 9) then you'll see "upgrade is ongoing", wait until it ends.
- 10) Player will restart automatically or press "Restart now" to restart, after restarting the upgrade ends.

B. Read out the software versions to confirm upgrading

- 4) In homemenu, enter "setup"->"advanced"->"version info", press "OK"

and other information will display on the TV screen as below:

Model:XXX.XXX
 Versions
 subinfo:xxxx
 system SW:xxxx
 ethernet MAC:xxxxxxxx
<http://www.philips.com/support>

Caution: The set must not be power off during upgrading, otherwise the Main board will be damaged entirely.

2.0 Safety instruction

1. General safety

Safety regulations require that during a repair:

- . Connect the unit to the mains via an isolation transformer.
- . Replace safety components indicated by the symbol
Only by components identical to the original ones.
- Any
Other component substitution (other than original type)
May increase risk of fire or electrical shock hazard.

Safety regulations require that after a repair, you must

Return the unit in its original condition. Pay, in particular,

Attention to the following points:

- . Route the wires/cables correctly, and fix them with the
mounted cable clamps
- . Check the insulation of the mains lead for external
Damage
- . Check the electrical DC resistance between the
mains

Plug and the secondary side:

- 1) Unplug the mains cord, and connect a wire between
The two pins of the mains plug.
- 2) Set the mains switch the "on" position (keep the
Mains cord unplug).
- 3) Measure the resistance value between the
mains
plug and the front panel, controls, and chassis
bottom.
- 4) Repair or correct unit when the resistance
measurement is less than 1M Ω
- 5) Verify this, before you return the unit to the
customer/user (ref. UL-standard no. 1492).
- 6) Switch the unit "off", and remove the wire
between
the two pins of the mains plug.

2. Laser safety

This unit employs a laser. Only qualified service personnel

May remove the cover, or attempt to service this device

(due to possible eye injury).

Laser device unit

Type :Semiconductor laser GaAlAs

Wavelength :650nm (DVD)

:780nm (VCD/CD)

Output power :7mW(DVD)

:10mW(DVD/CD)

Beam divergence:60 degree

Note: Use of controls or adjustments or performance of procedure other than those specified herein, may result in hazardous radiation exposure. Avoid direct exposure to beam.

3.0 Instruction for Use

You can download this information from the following websites:

<http://www.philips.com/support>

<http://www.p4c.philips.com>

4.0 MECHANICAL AND DISMANTLING INSTRUCTIONS

The following guidelines show how to dismantle the player.

Step1: Remove 3 screws around the Top Cover, and then remove the Top Cover



Step2: Dismantling Front Panel, the CD door should be removed first, then gently pull the Panel out from the set.
use an acute press the reset hole to release the disc tray; remove the door from the tray;
PS: insert reset hole once the disc tray jammed

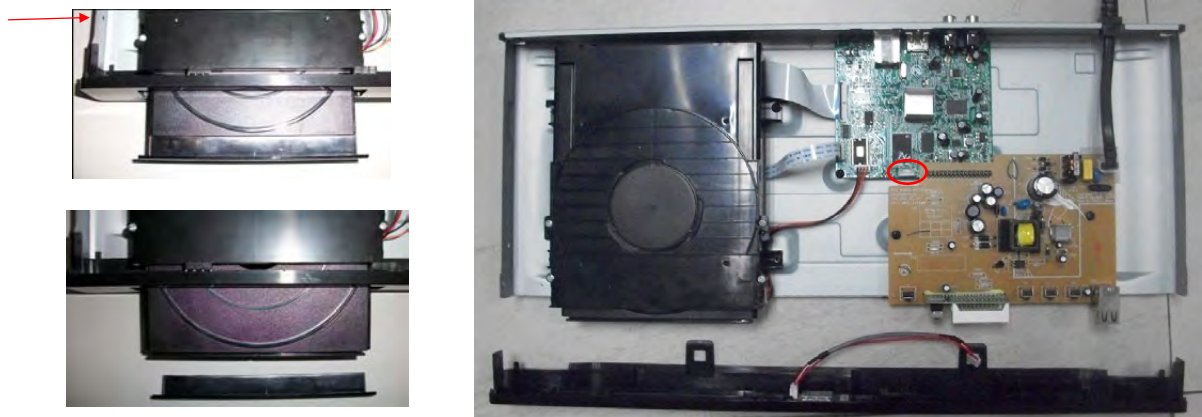

Step3: Remove the 9 screws on board to dismantle the DVD BOARD & PSU BOARD & DECK

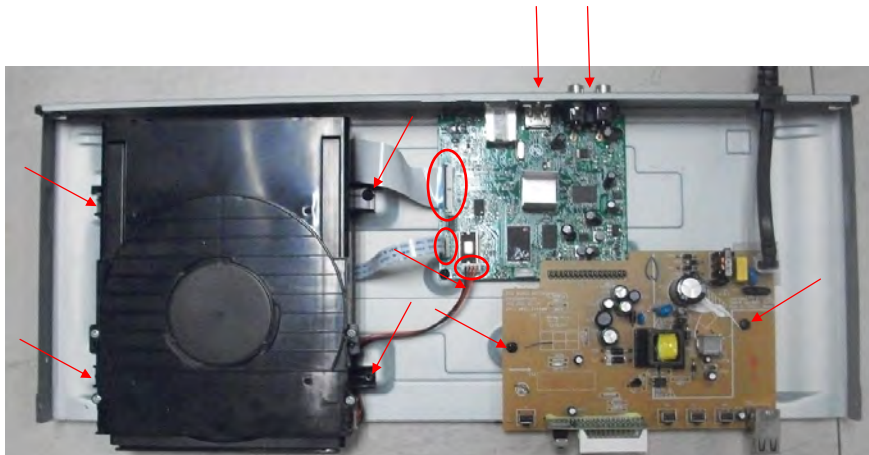

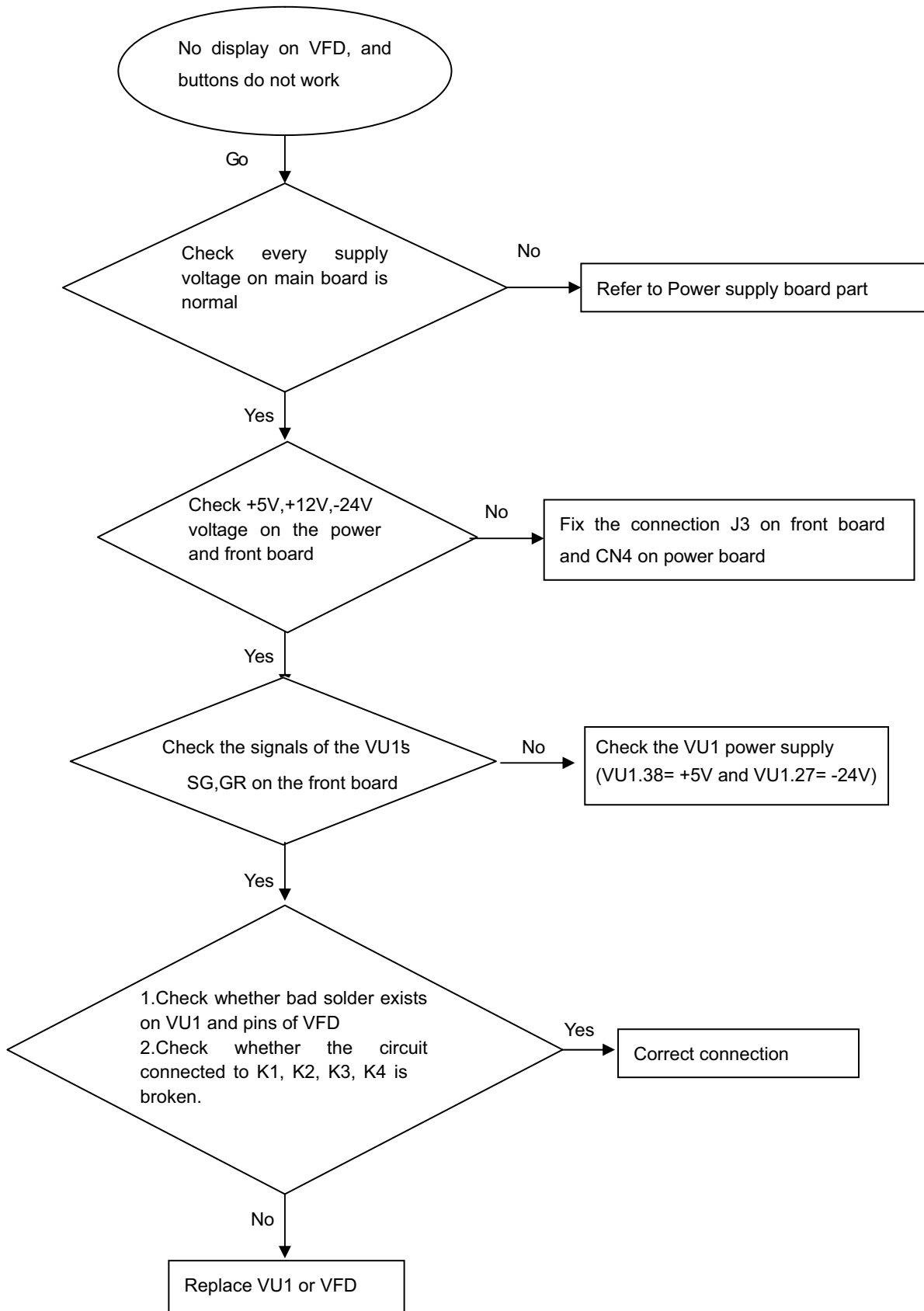
No display on VFD, and buttons do not work

No audio output

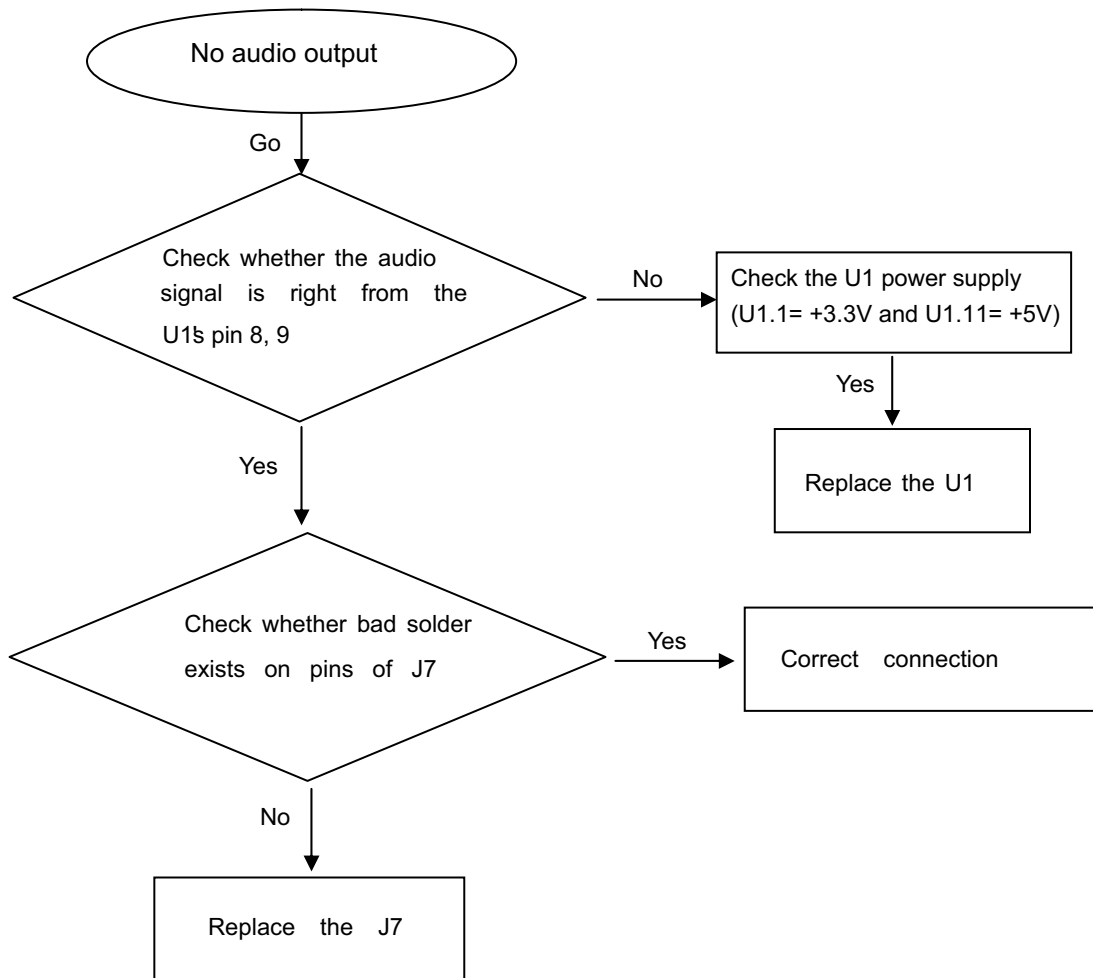

Remote control does not work

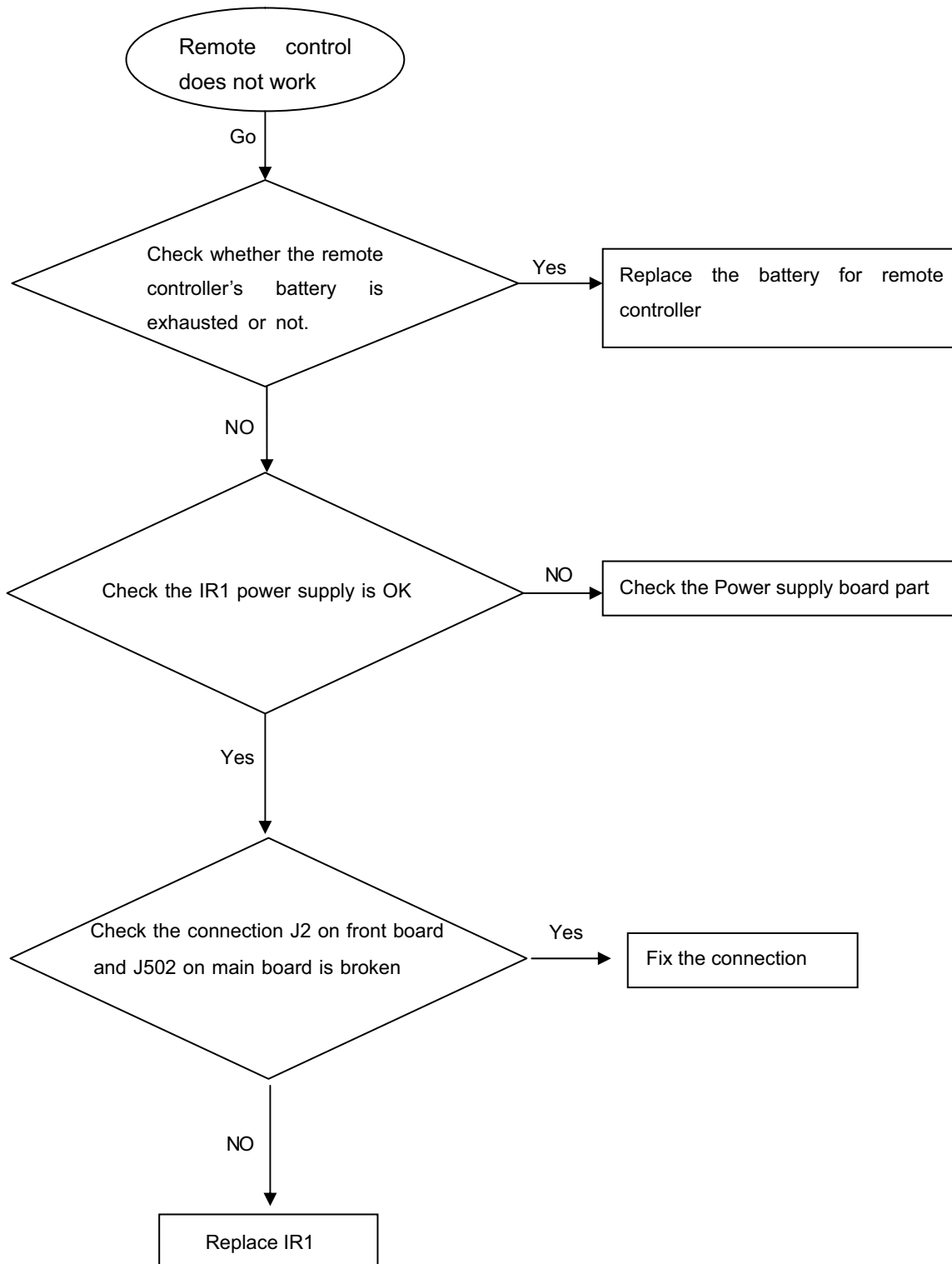

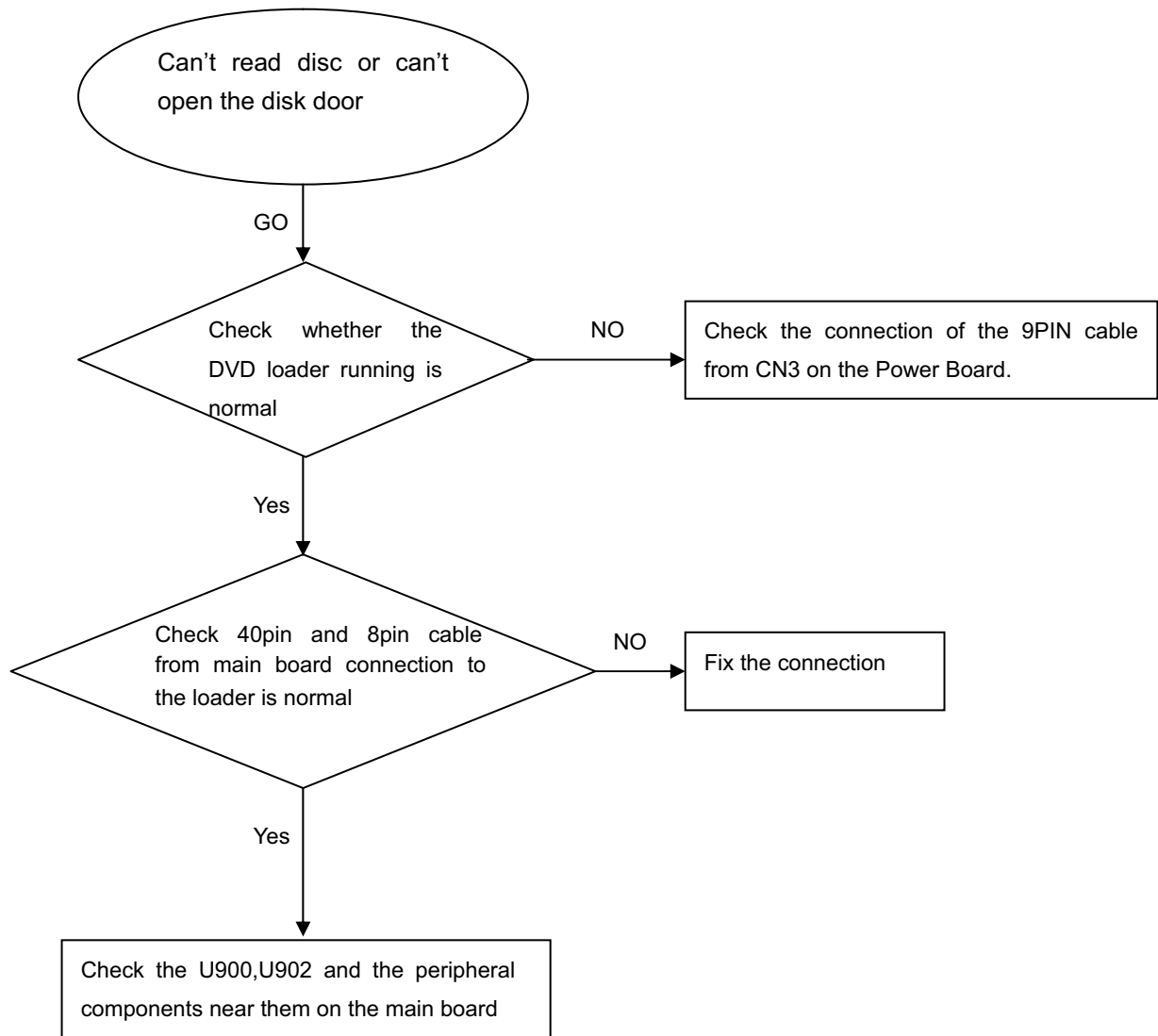
Can't read disc or can't open the disk door

No VFD display

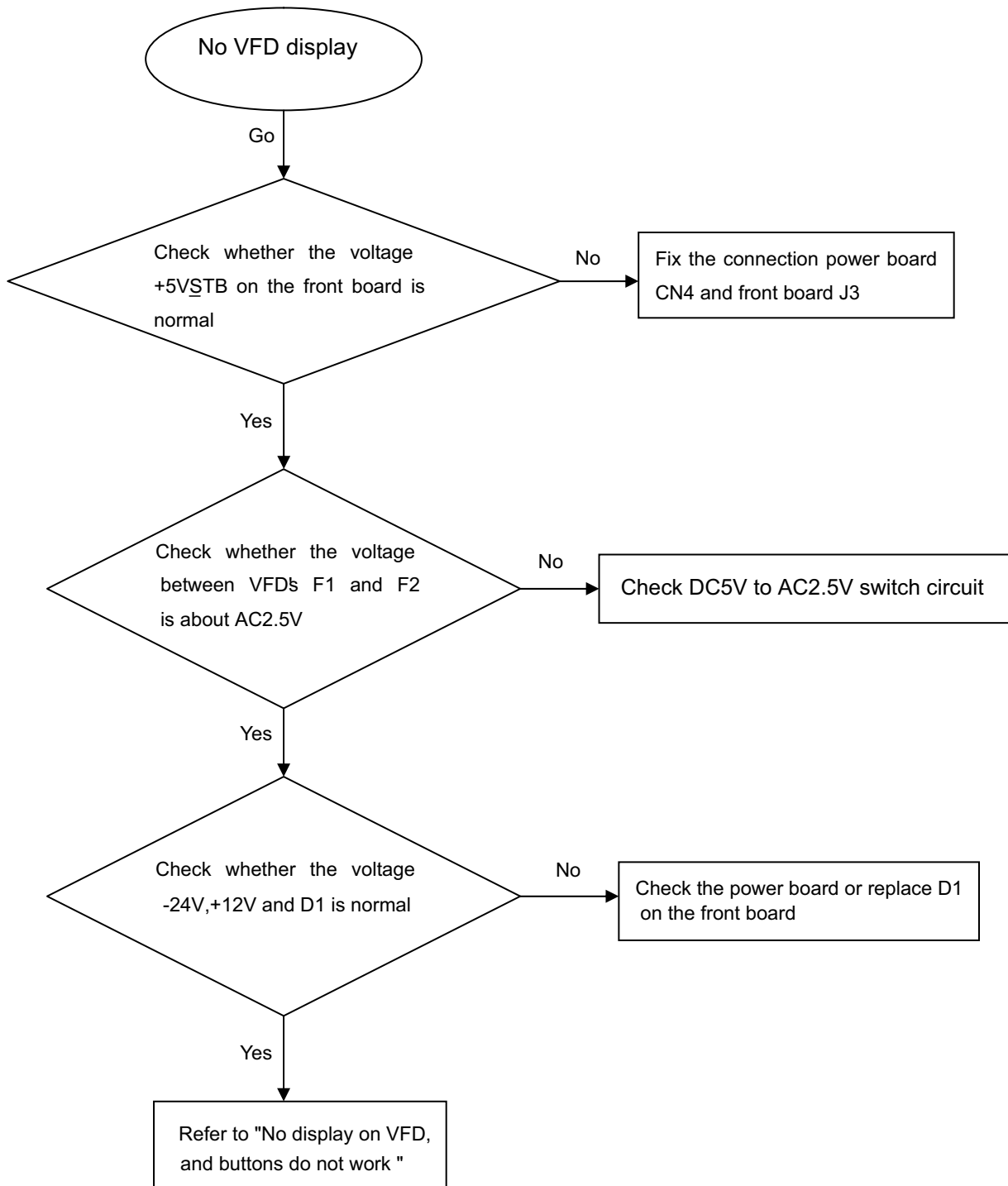

OVERALL BLOCK DIAGRAM

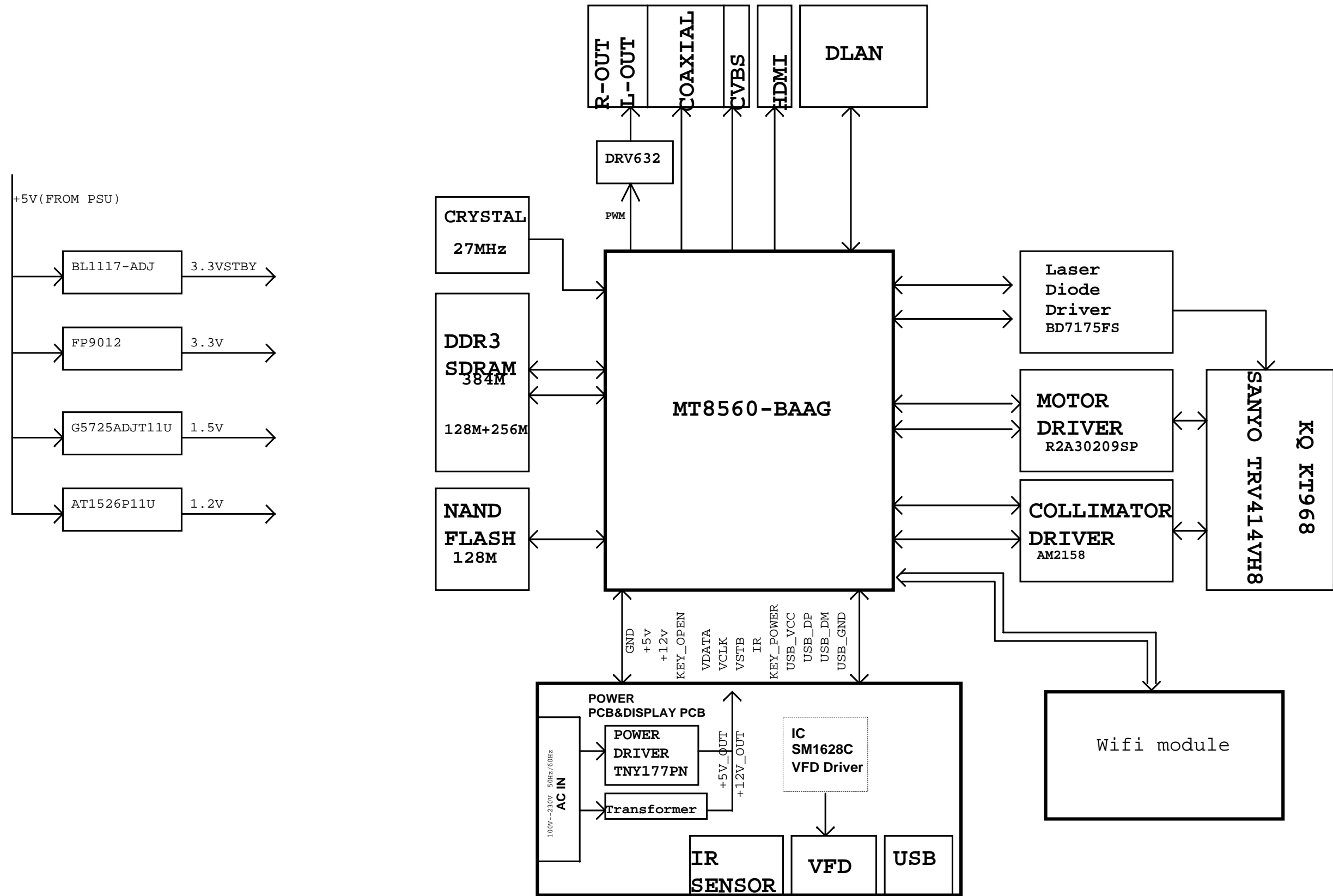

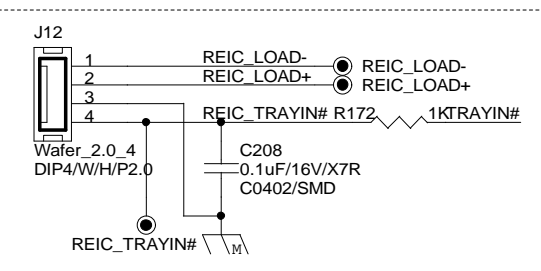
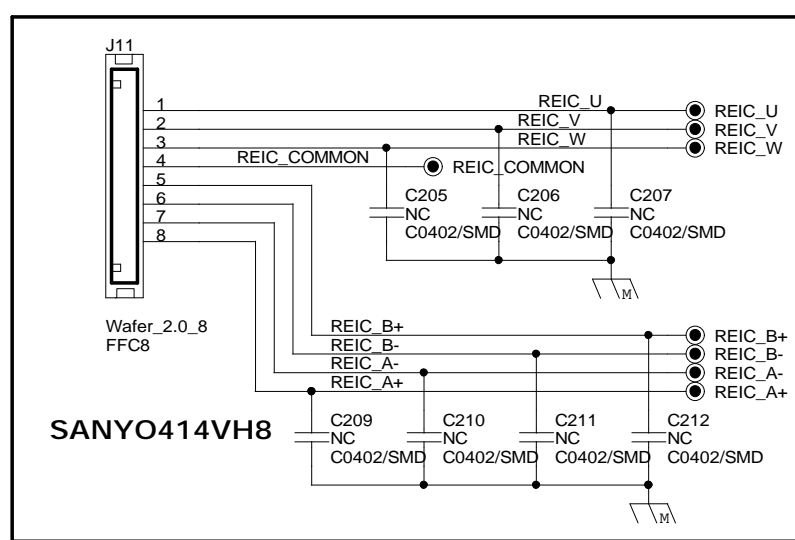
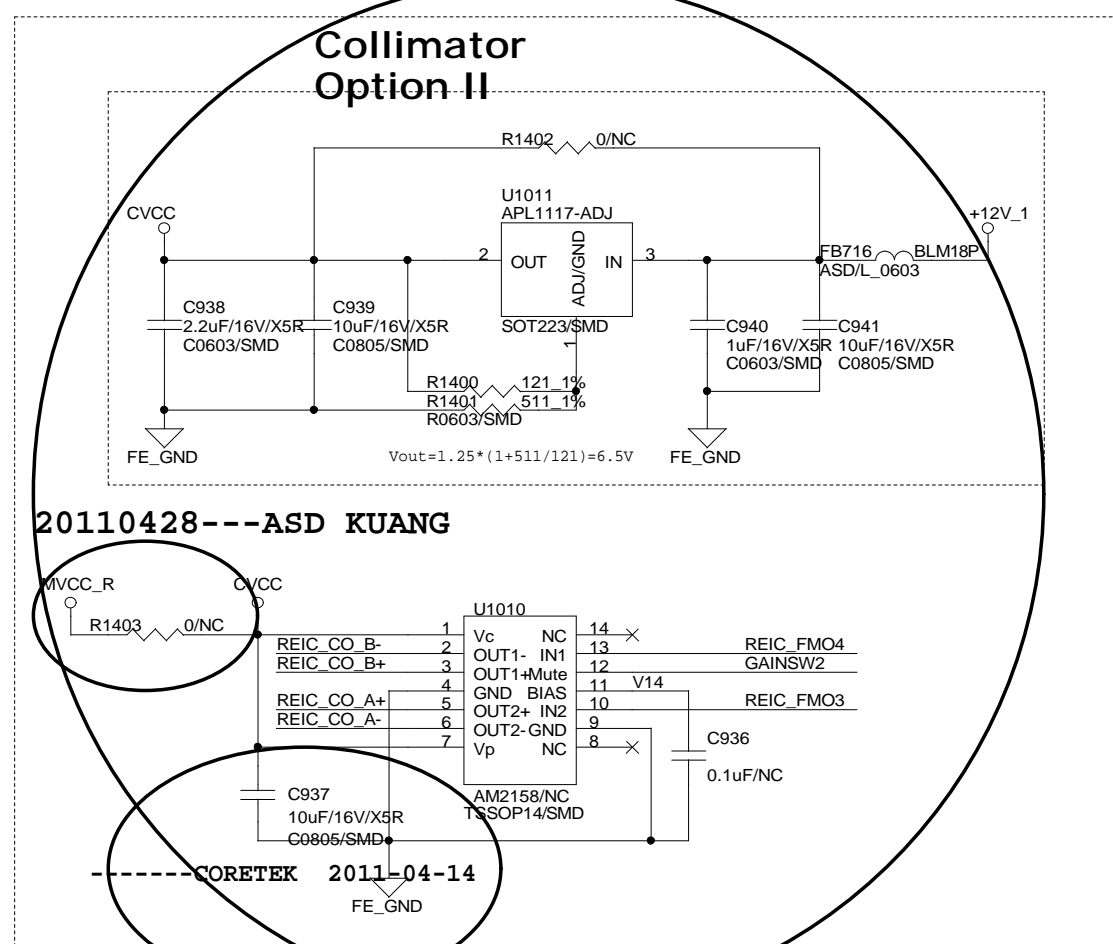
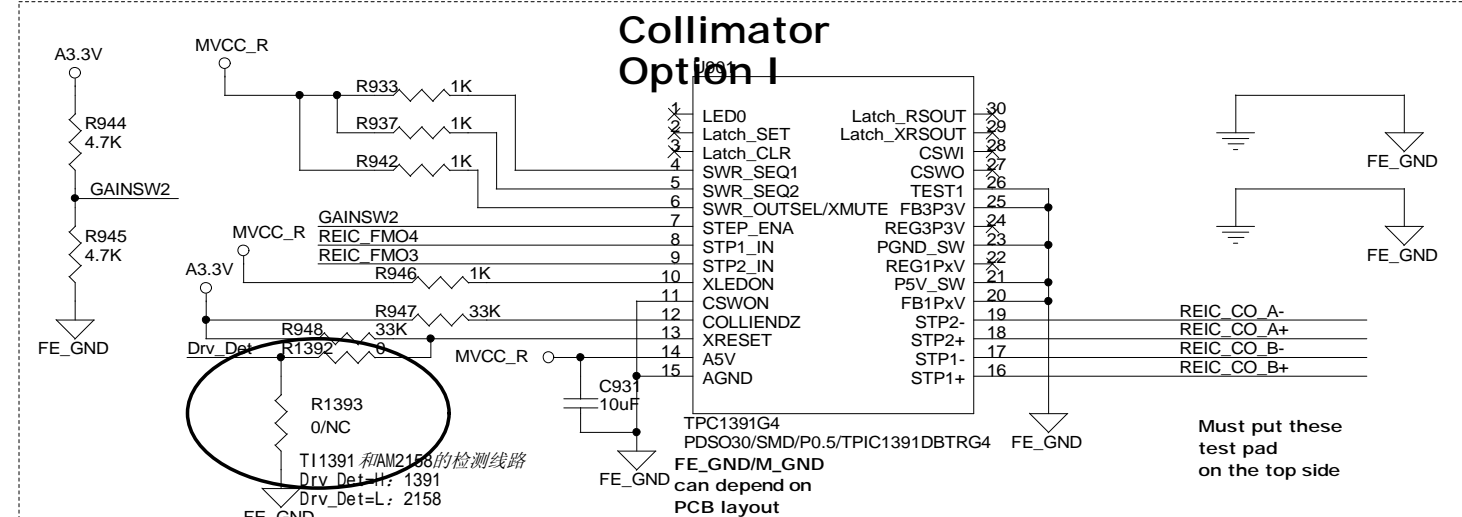
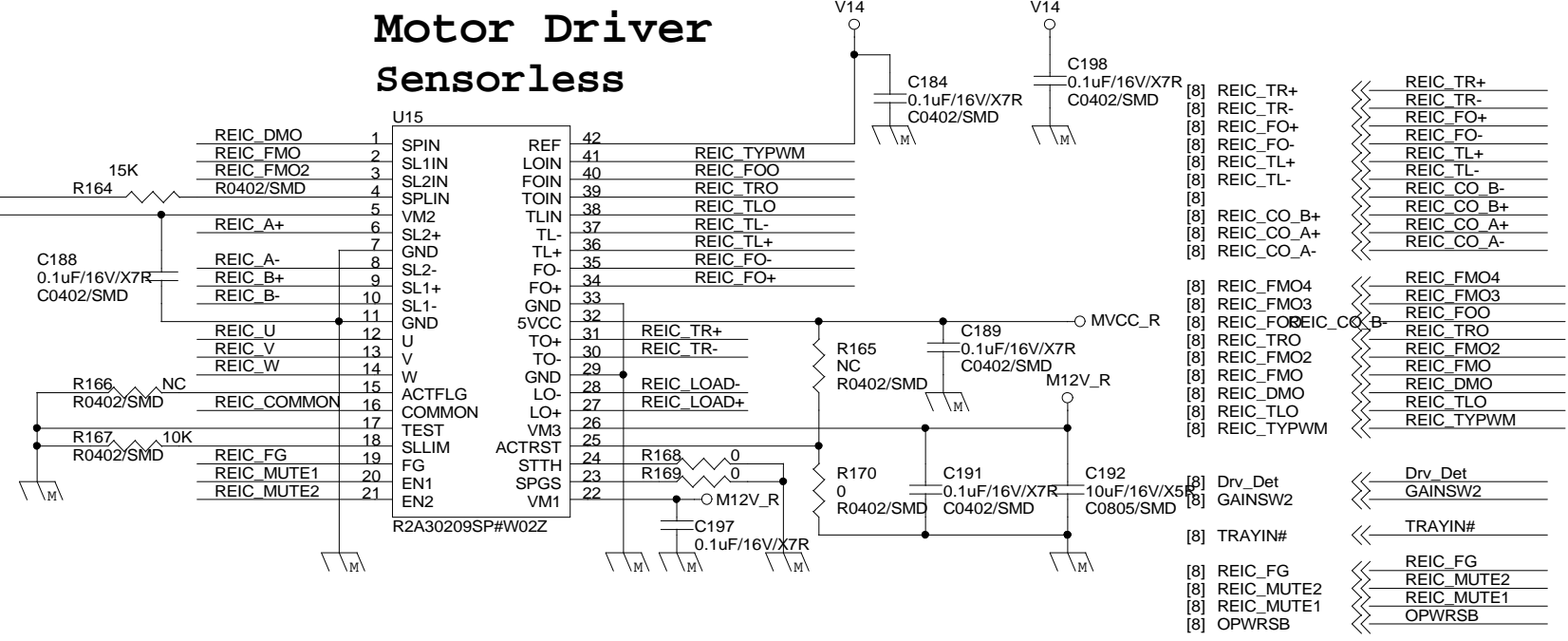
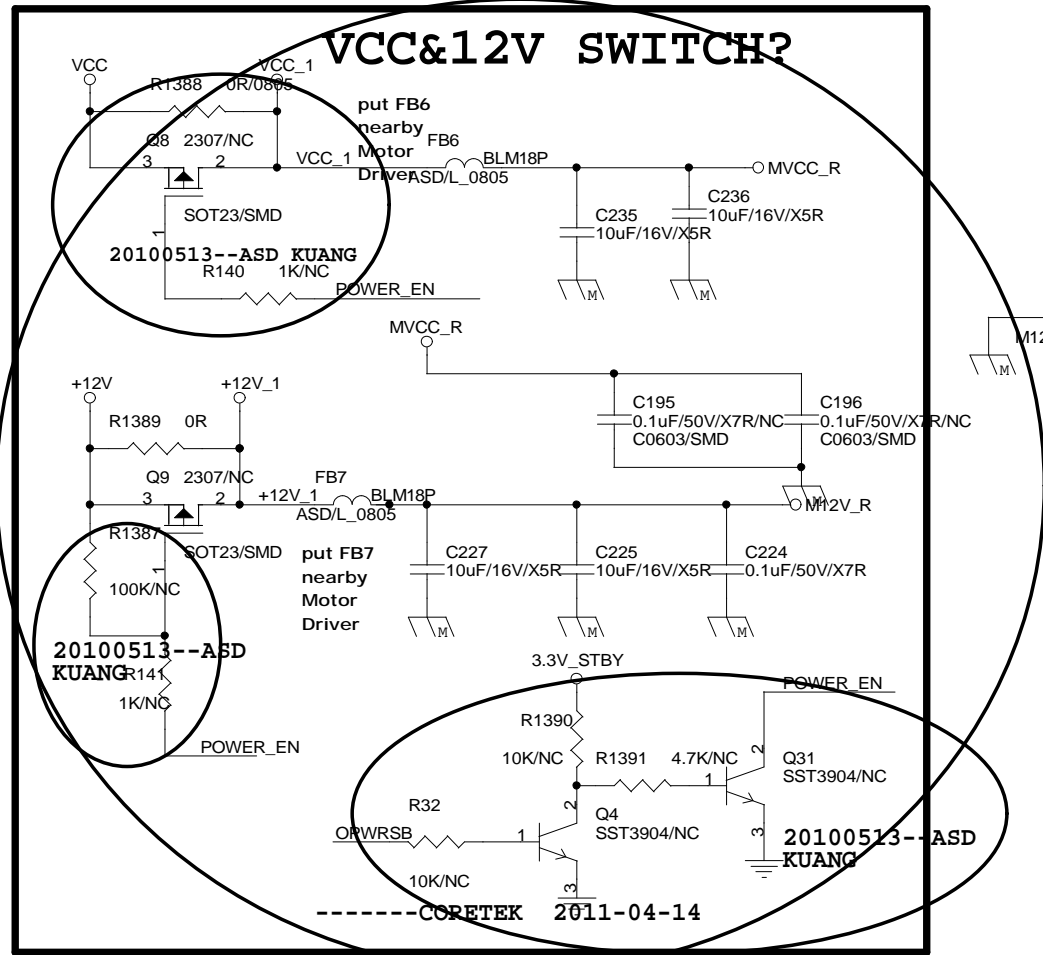

CIRCUIT DIAGRAM-DVD Main Board

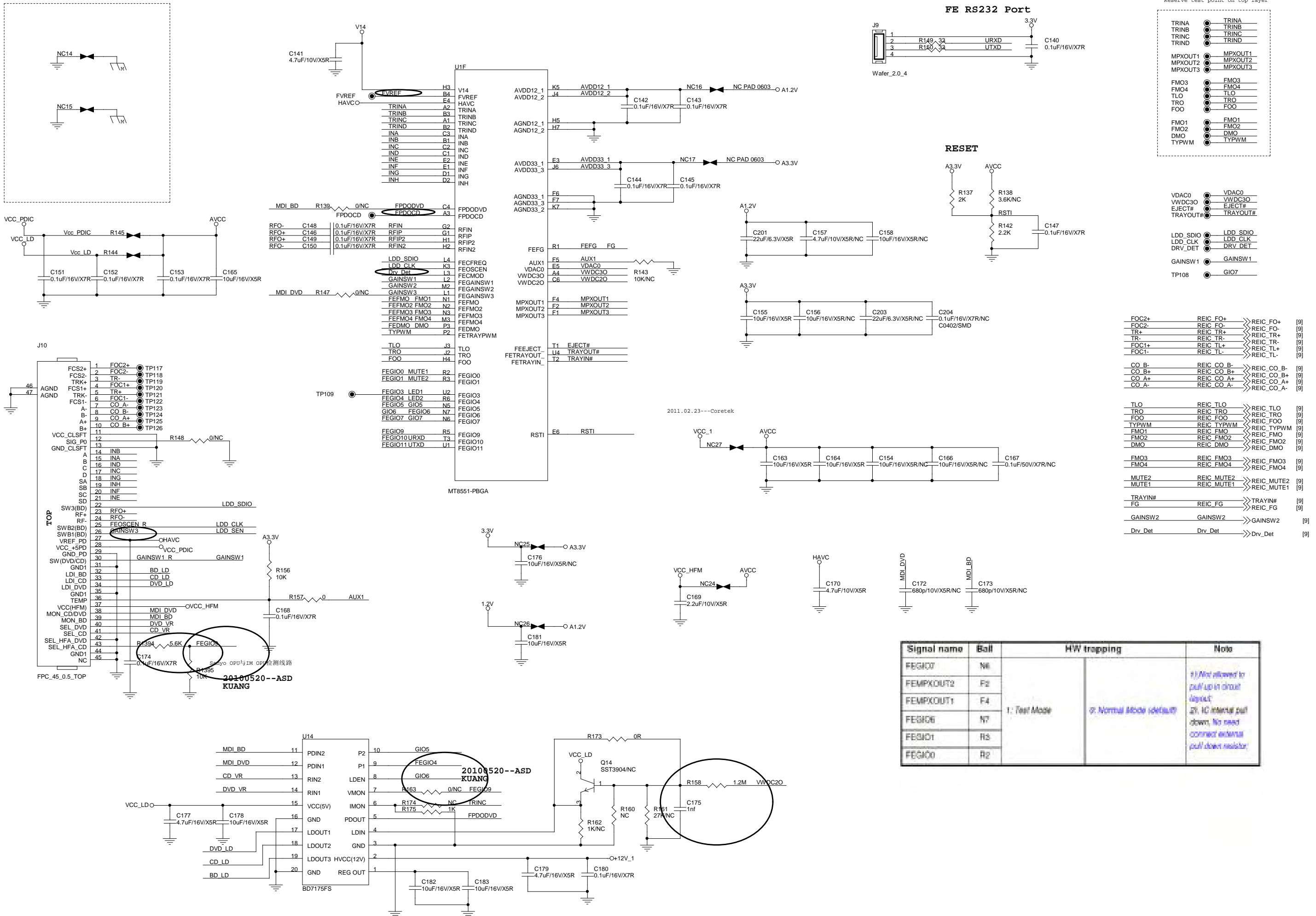

CIRCUIT DIAGRAM-DVD Main Board

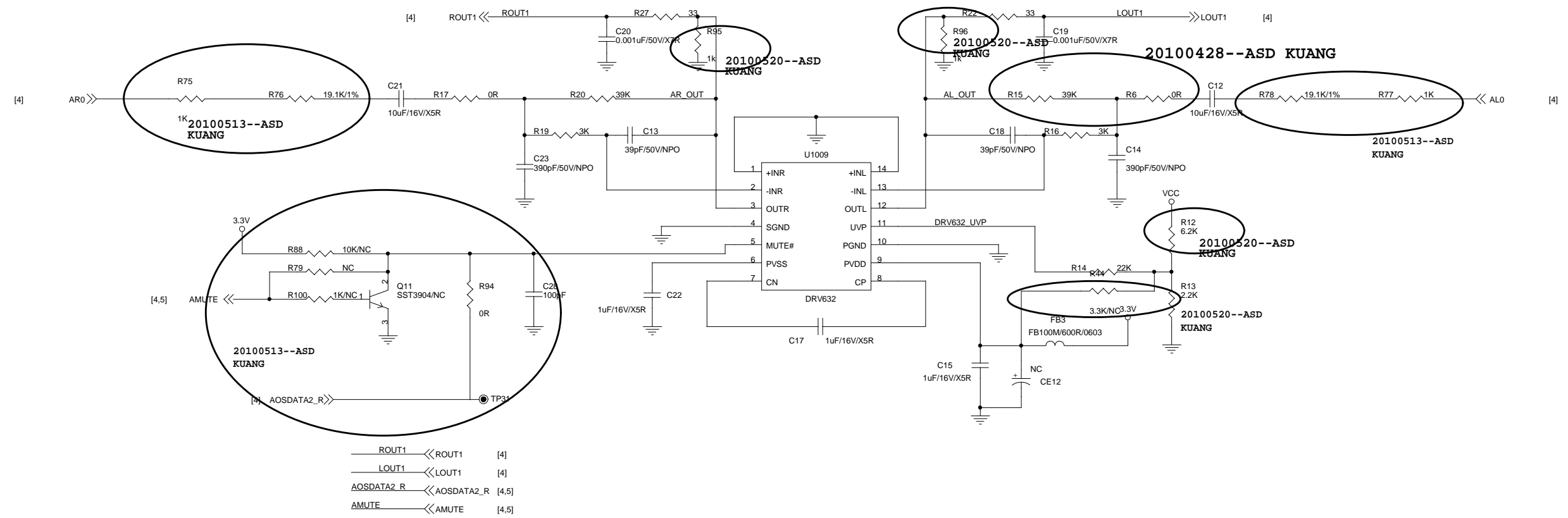

CIRCUIT DIAGRAM-DVD Main Board

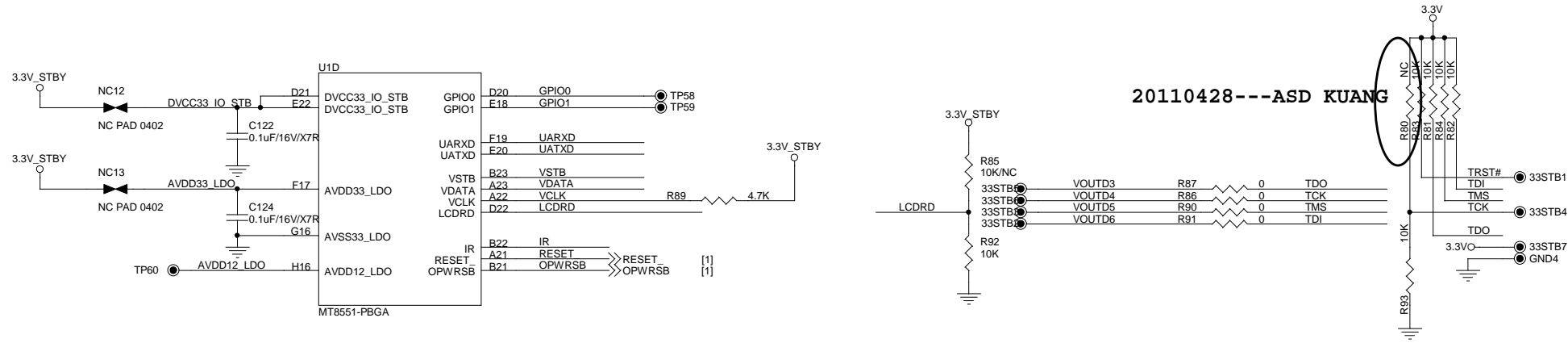

20110428---ASD KUANG

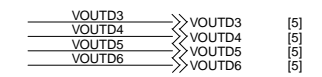
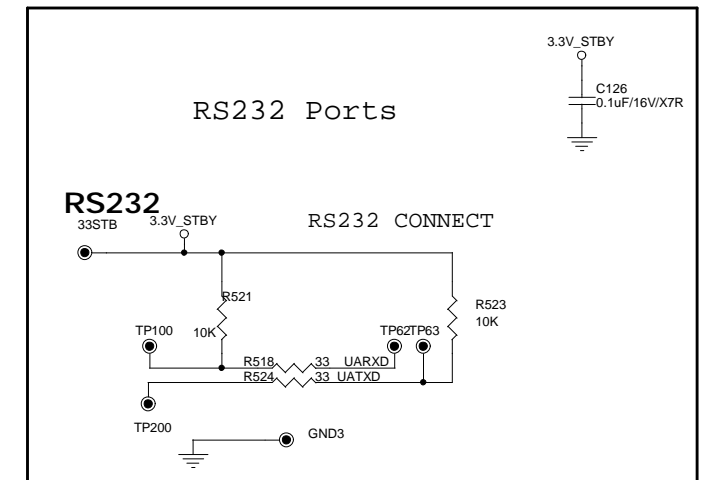
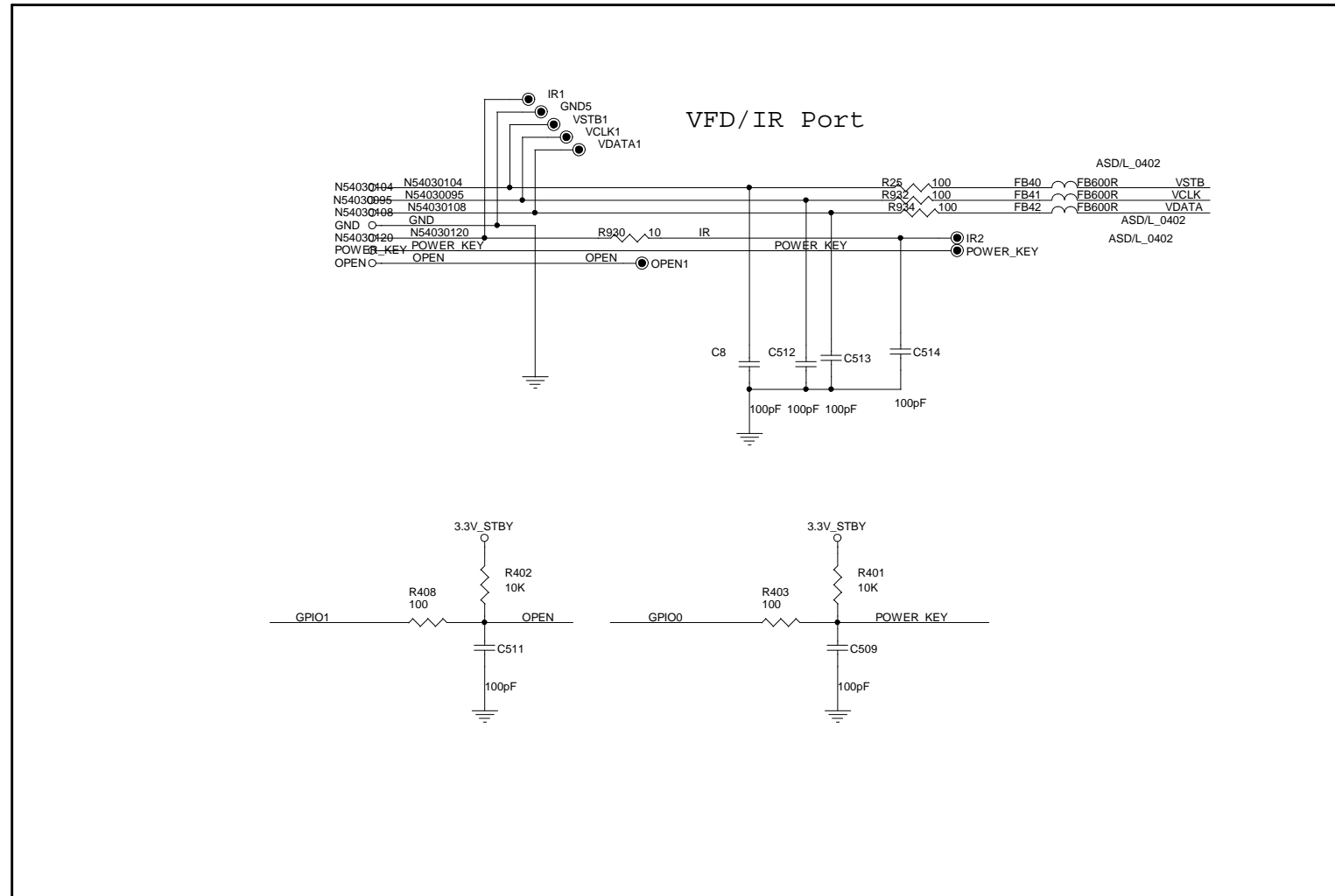

CIRCUIT DIAGRAM-DVD Main Board

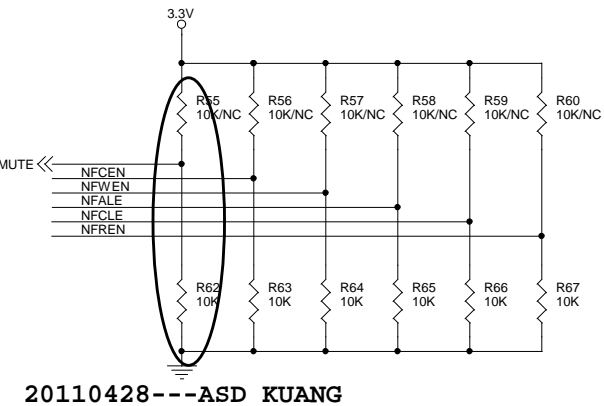
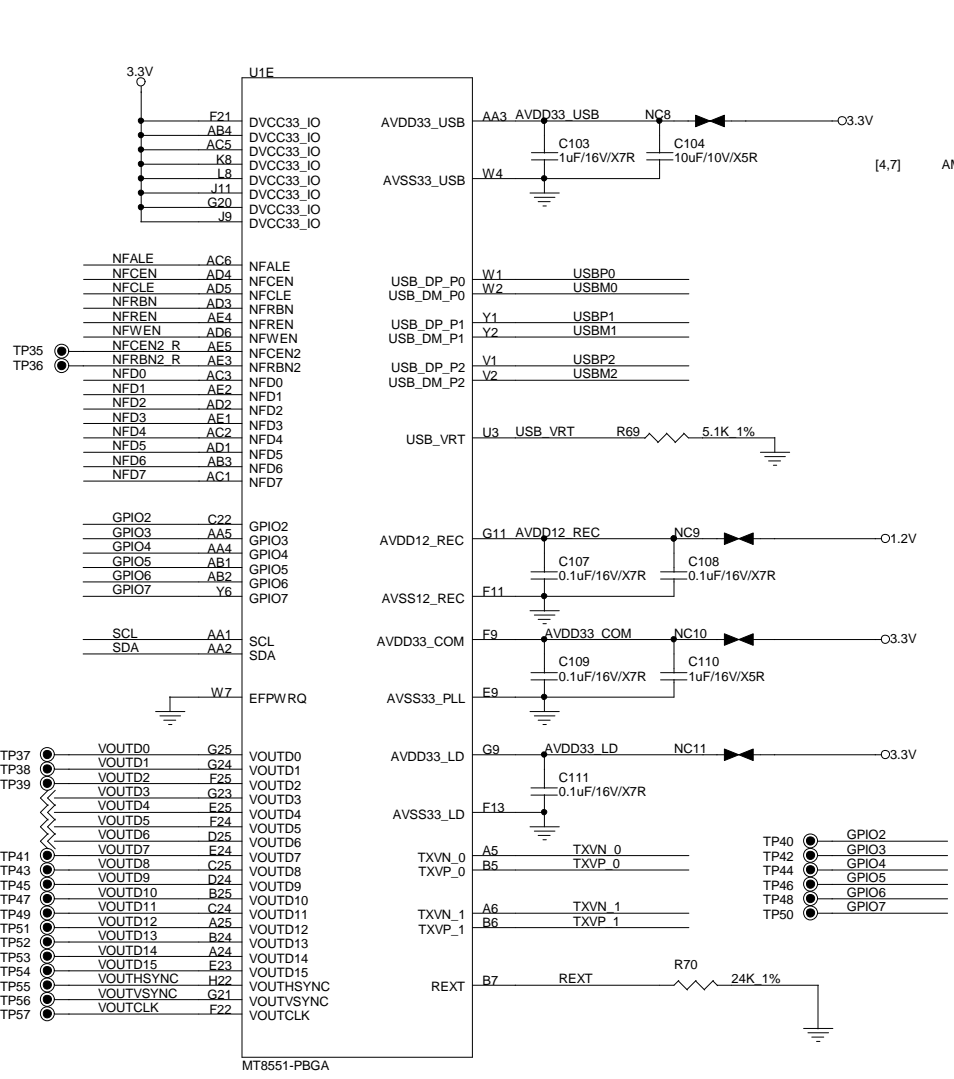

20110428---ASD KUANG

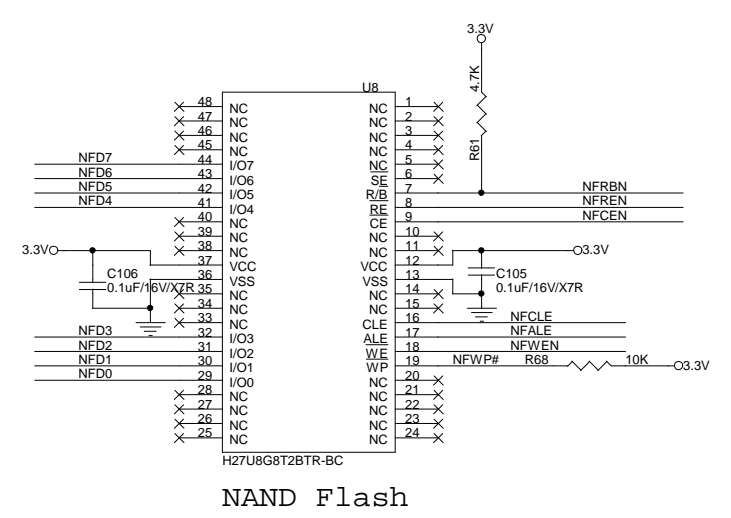

NAND Flash

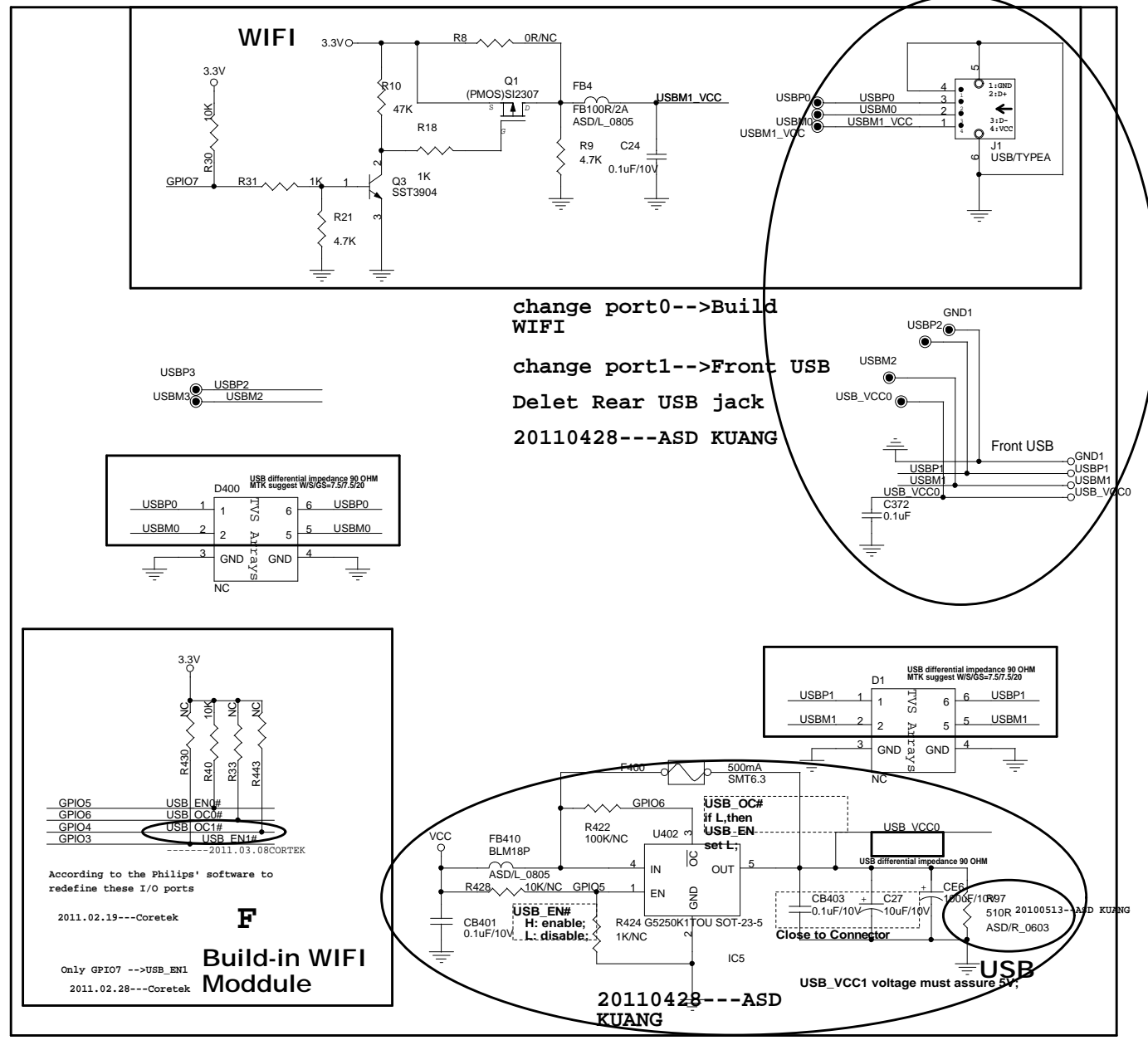

change port0-->Build WIFI
change port1-->Front USB
Delet Rear USB jack
20110428---ASD KUANG

Build-in WIFI Module
According to the Philips' software to redefine these I/O ports
2011.02.19---Coretek
2011.02.28---Coretek

20110428---ASD KUANG

USB_VCC1 voltage must assure 5V

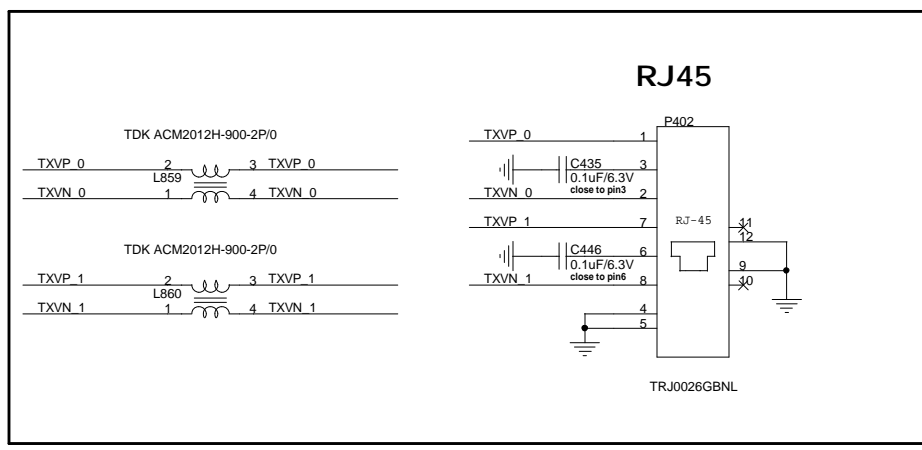
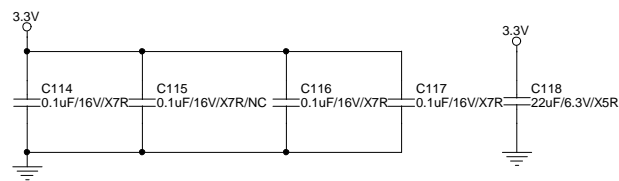
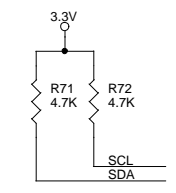

CIRCUIT DIAGRAM-DVD Main Board

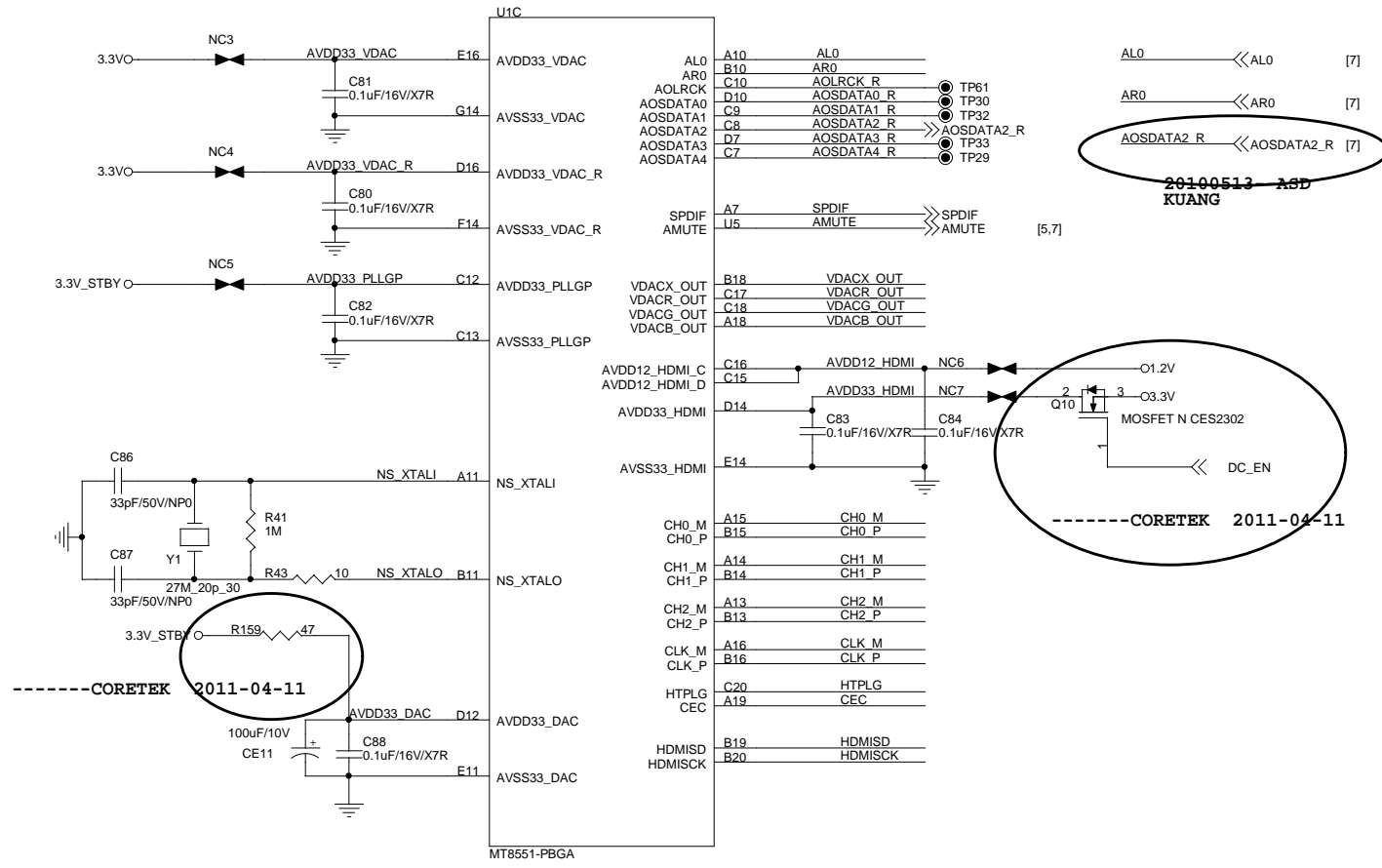

HDMI Port

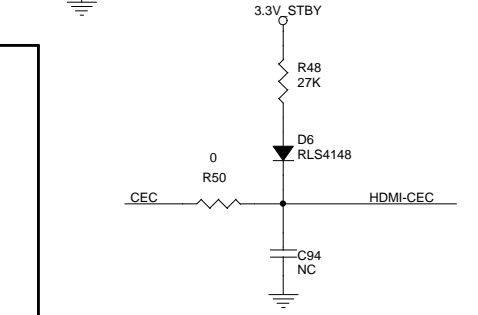
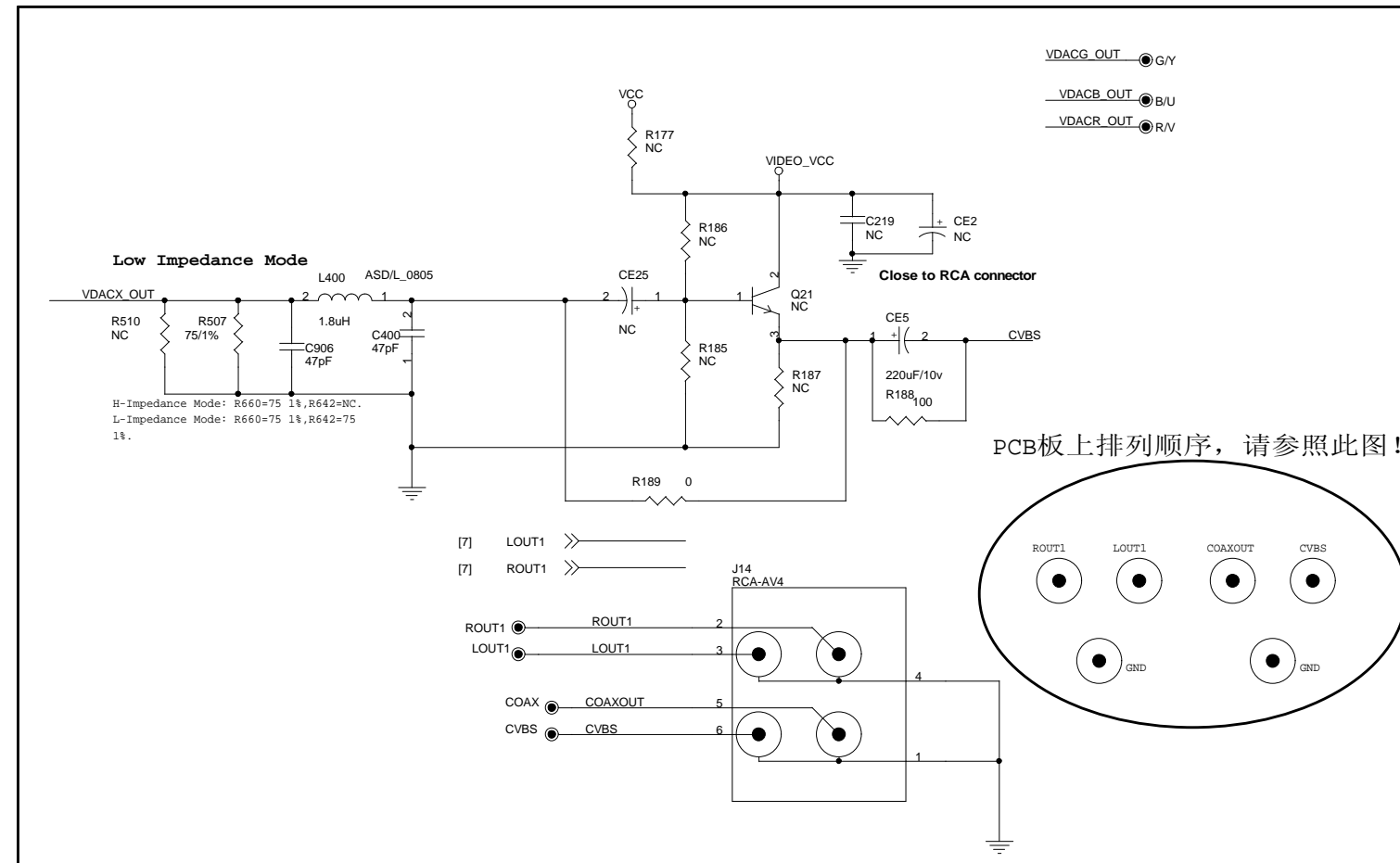
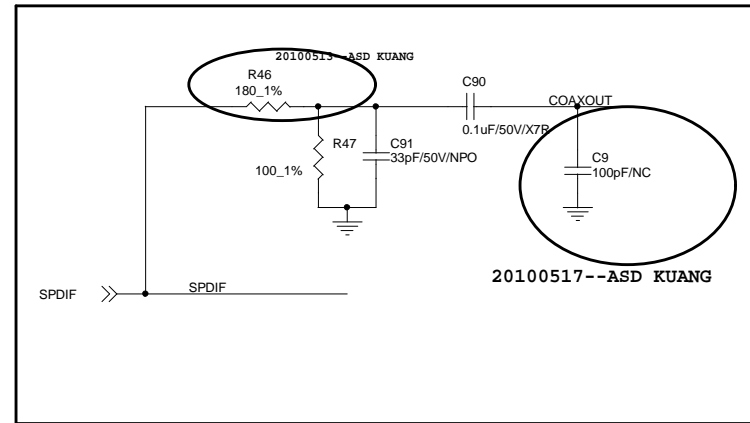
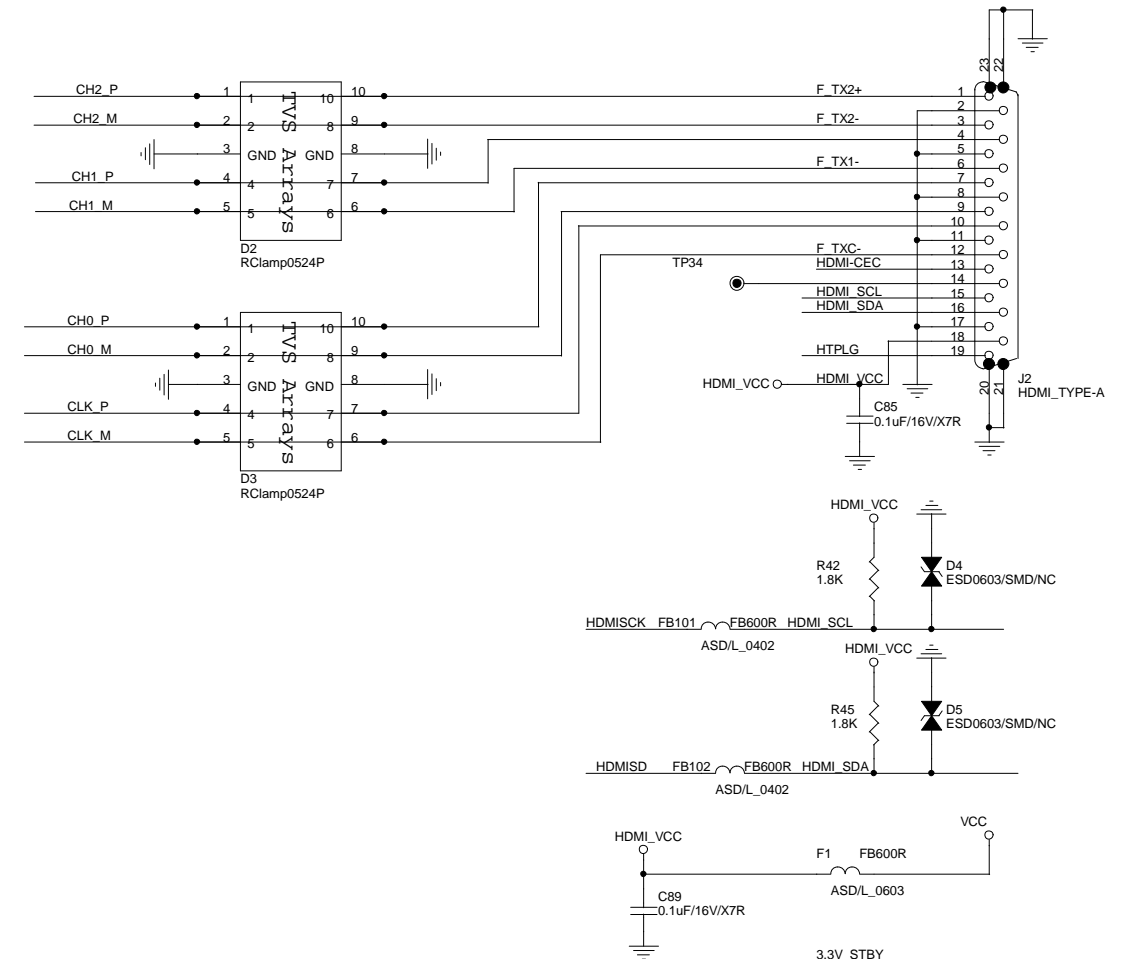

CIRCUIT DIAGRAM-DVD Main Board

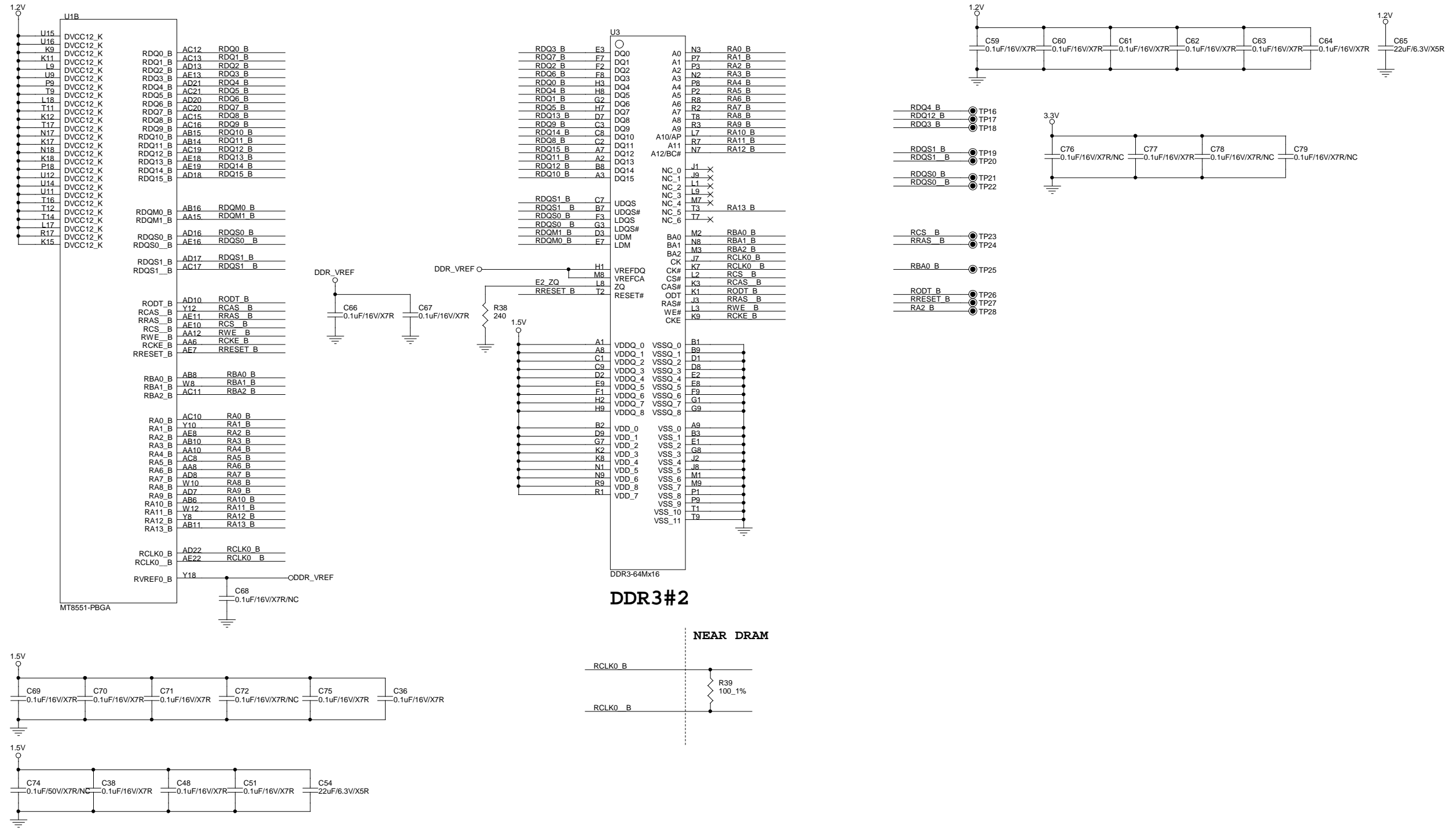

CIRCUIT DIAGRAM-DVD Main Board

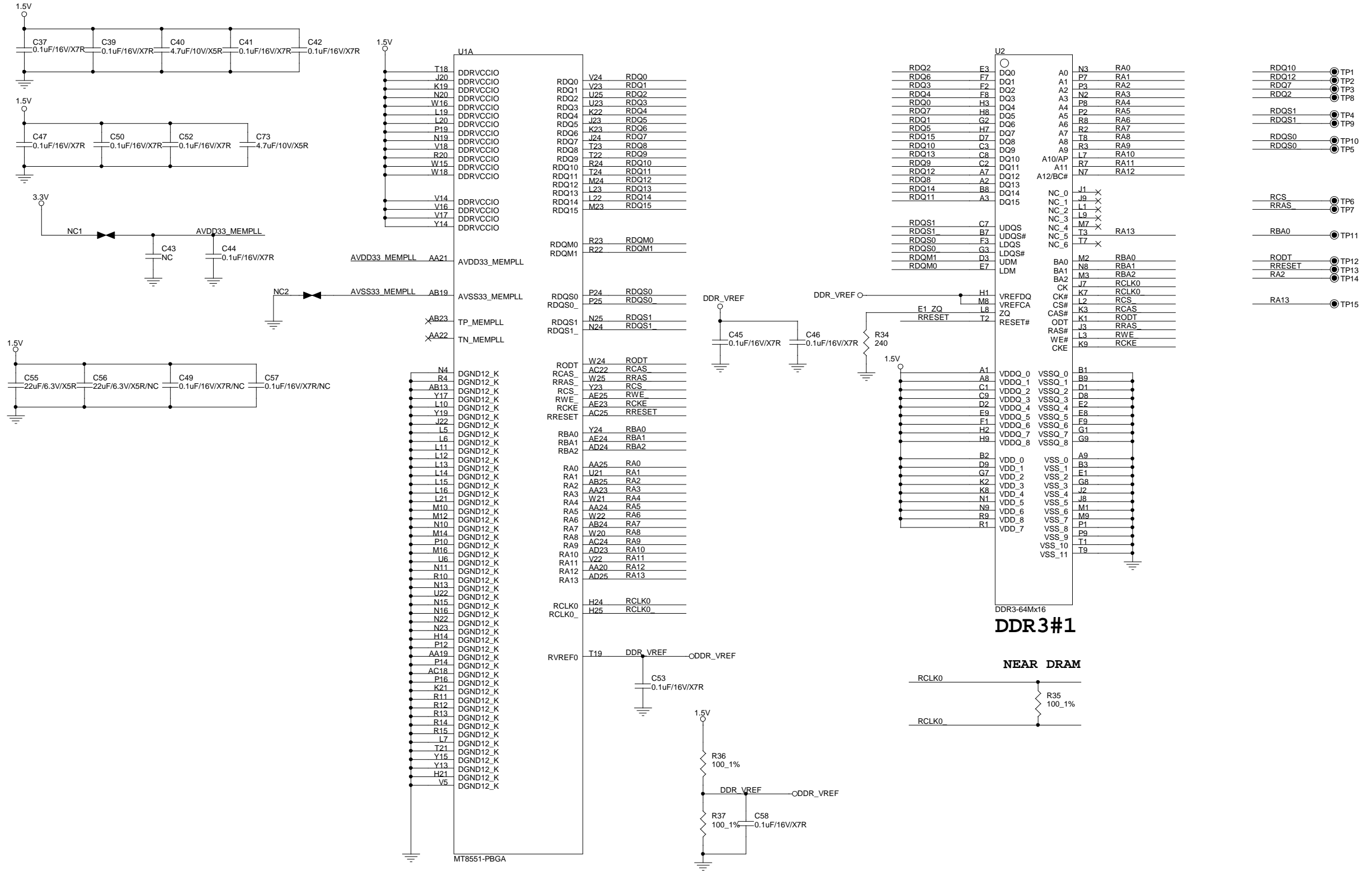

CIRCUIT DIAGRAM-DVD Main Board

MT8551 DDR3 Demo 1

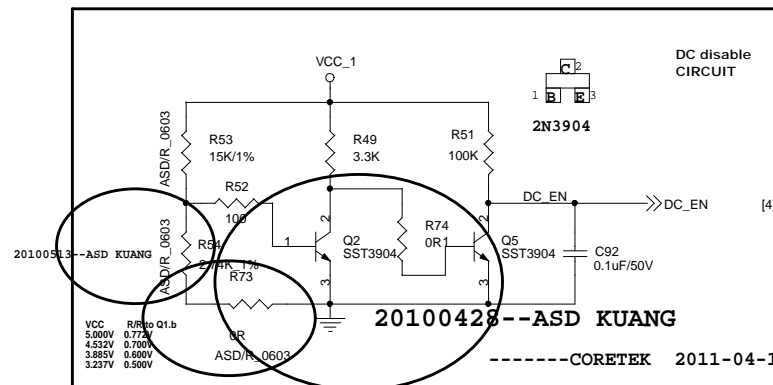
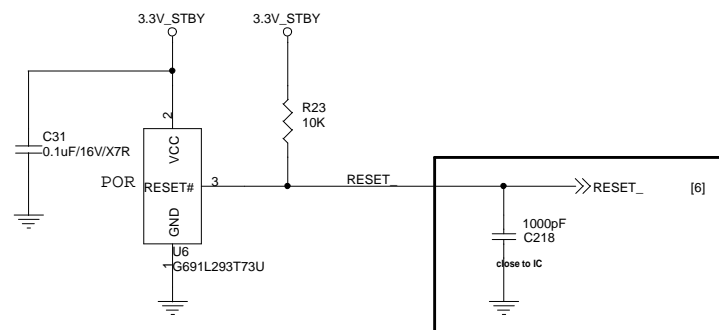
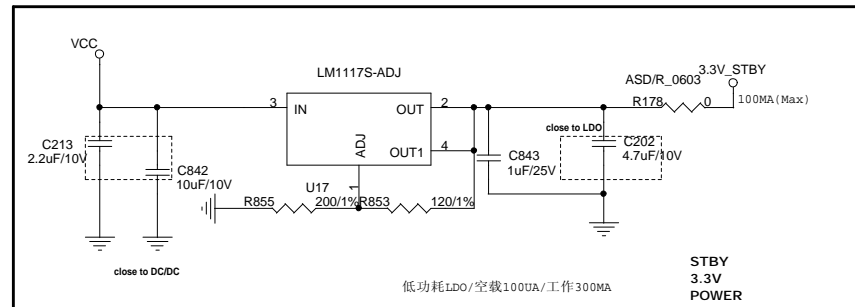
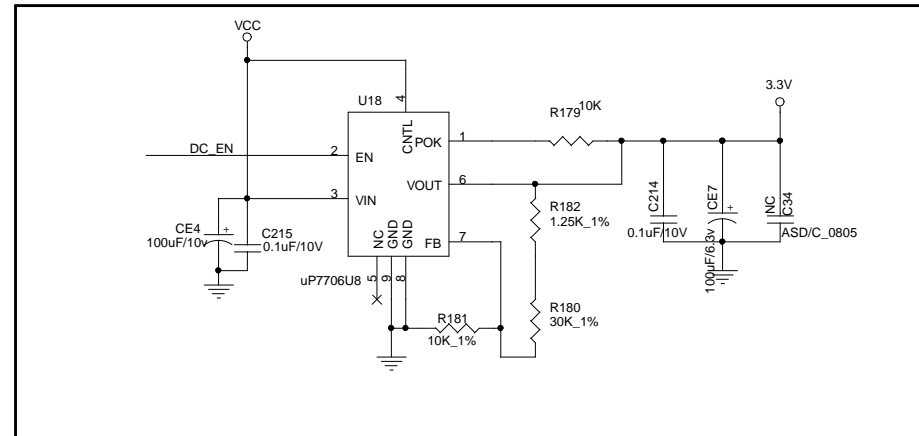
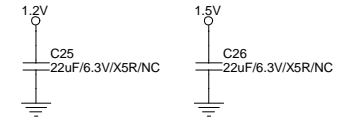
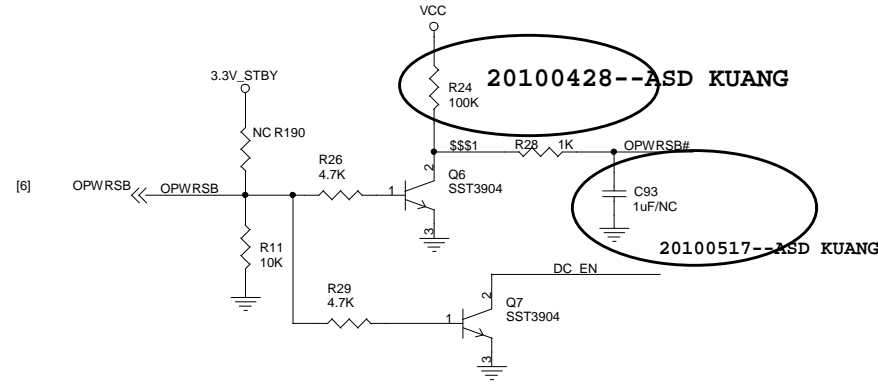
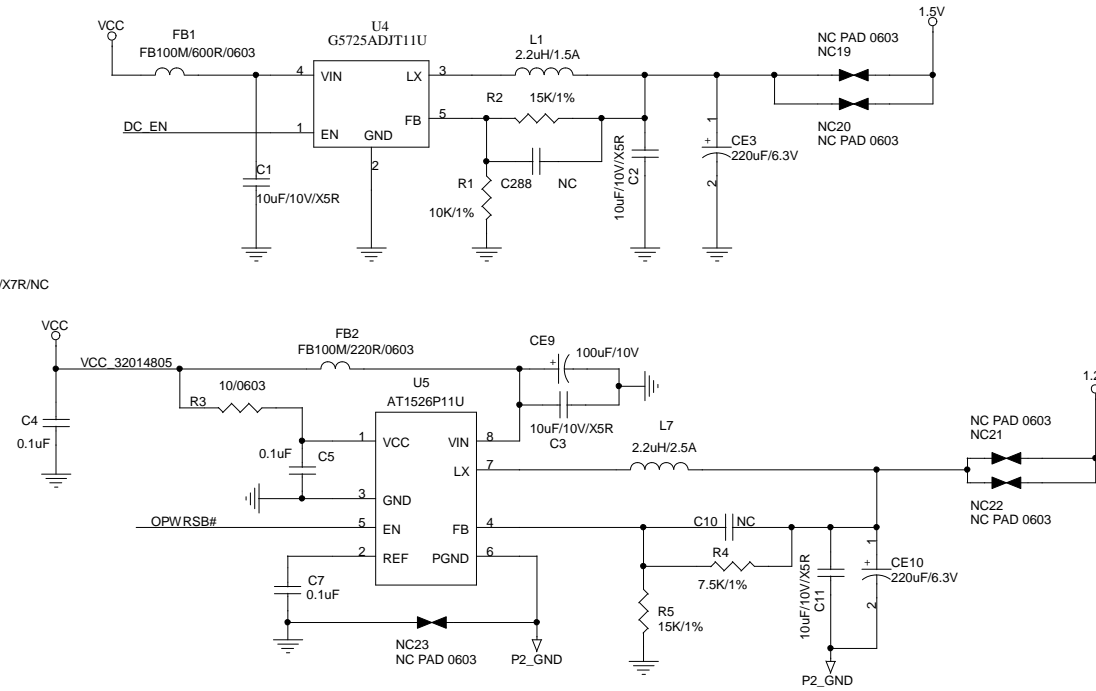
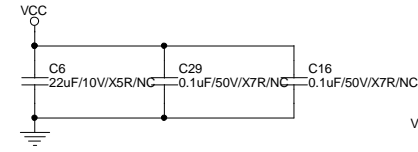
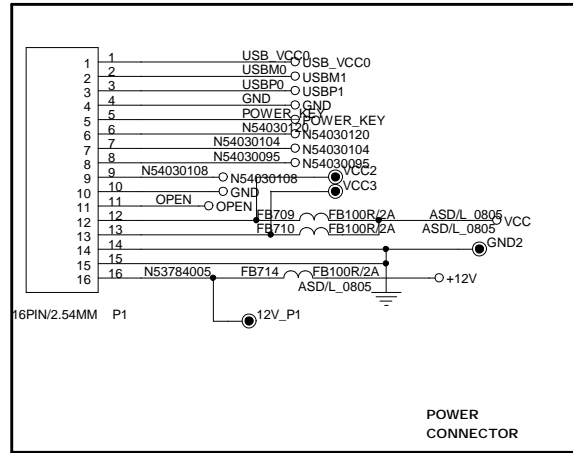

CIRCUIT DIAGRAM-PSU Board

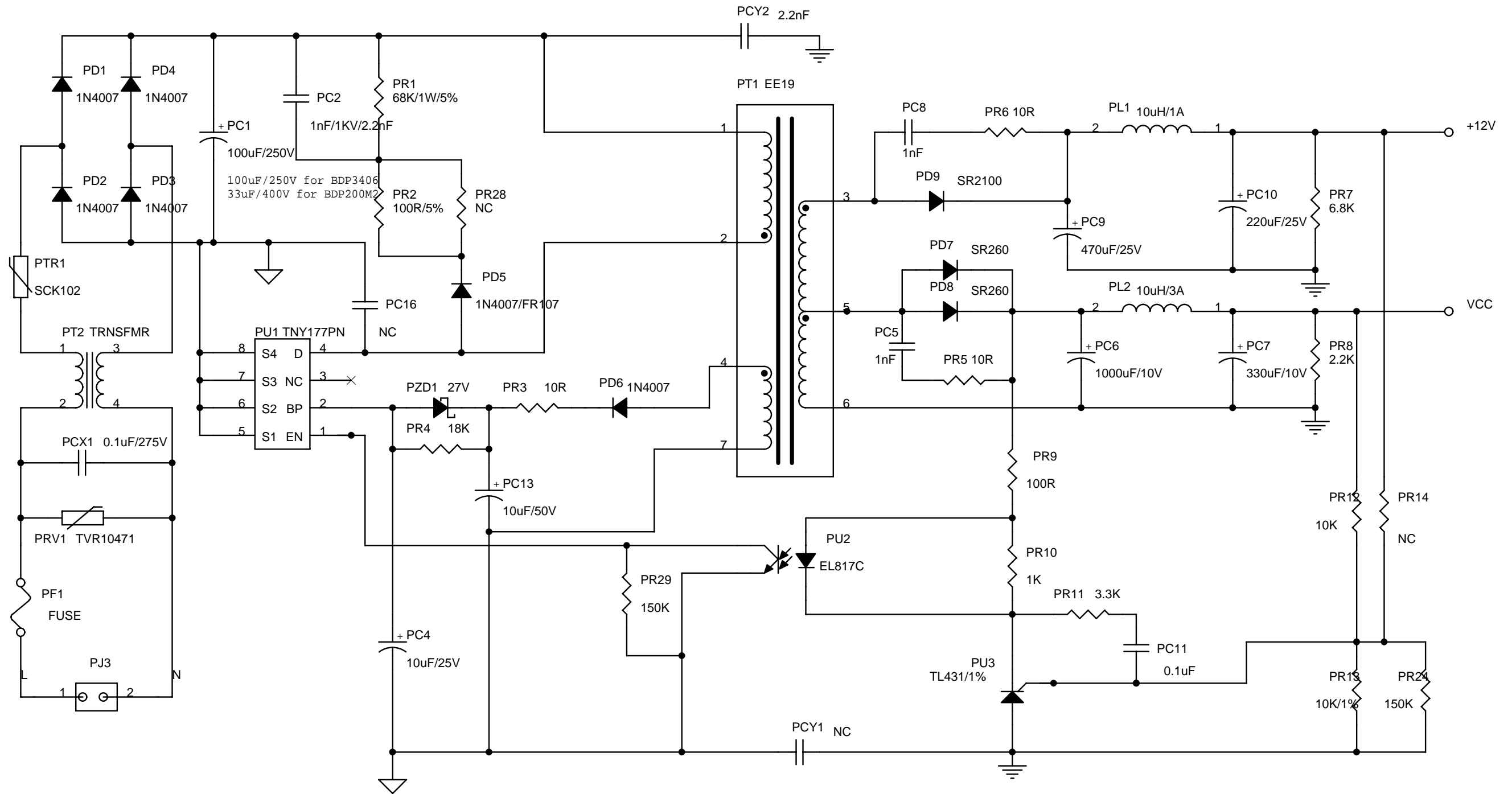

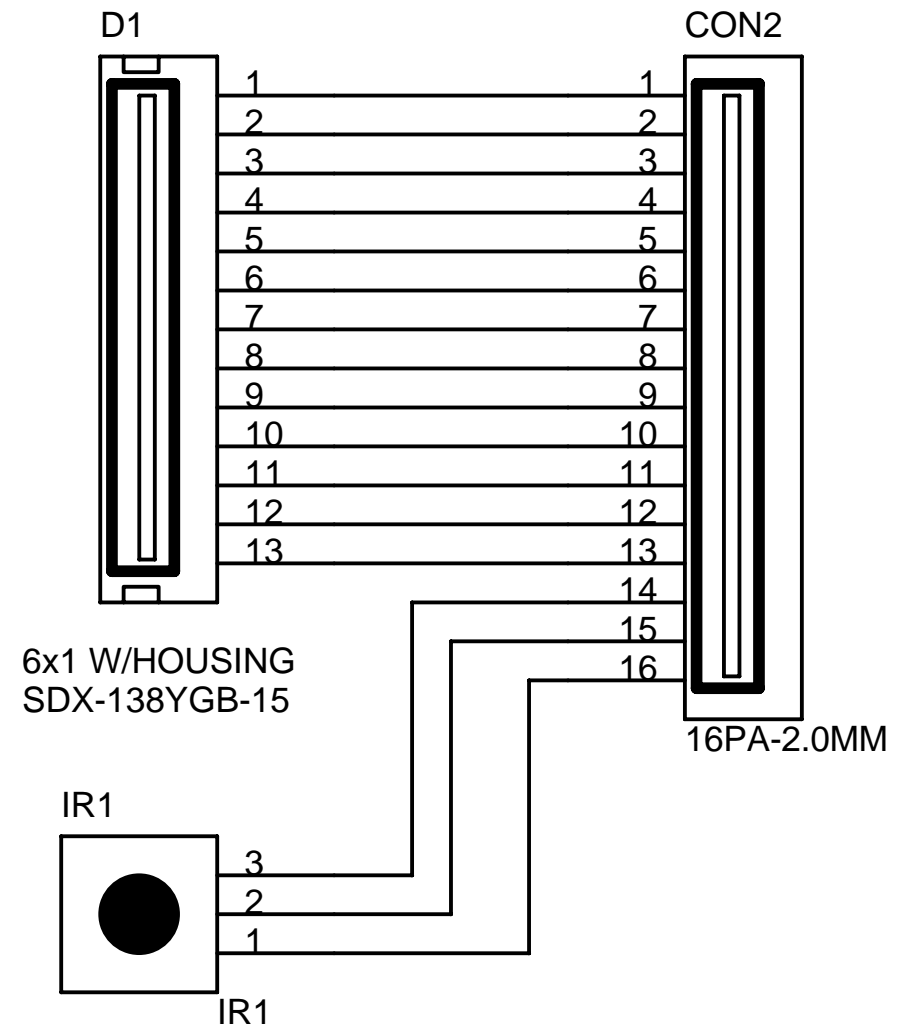

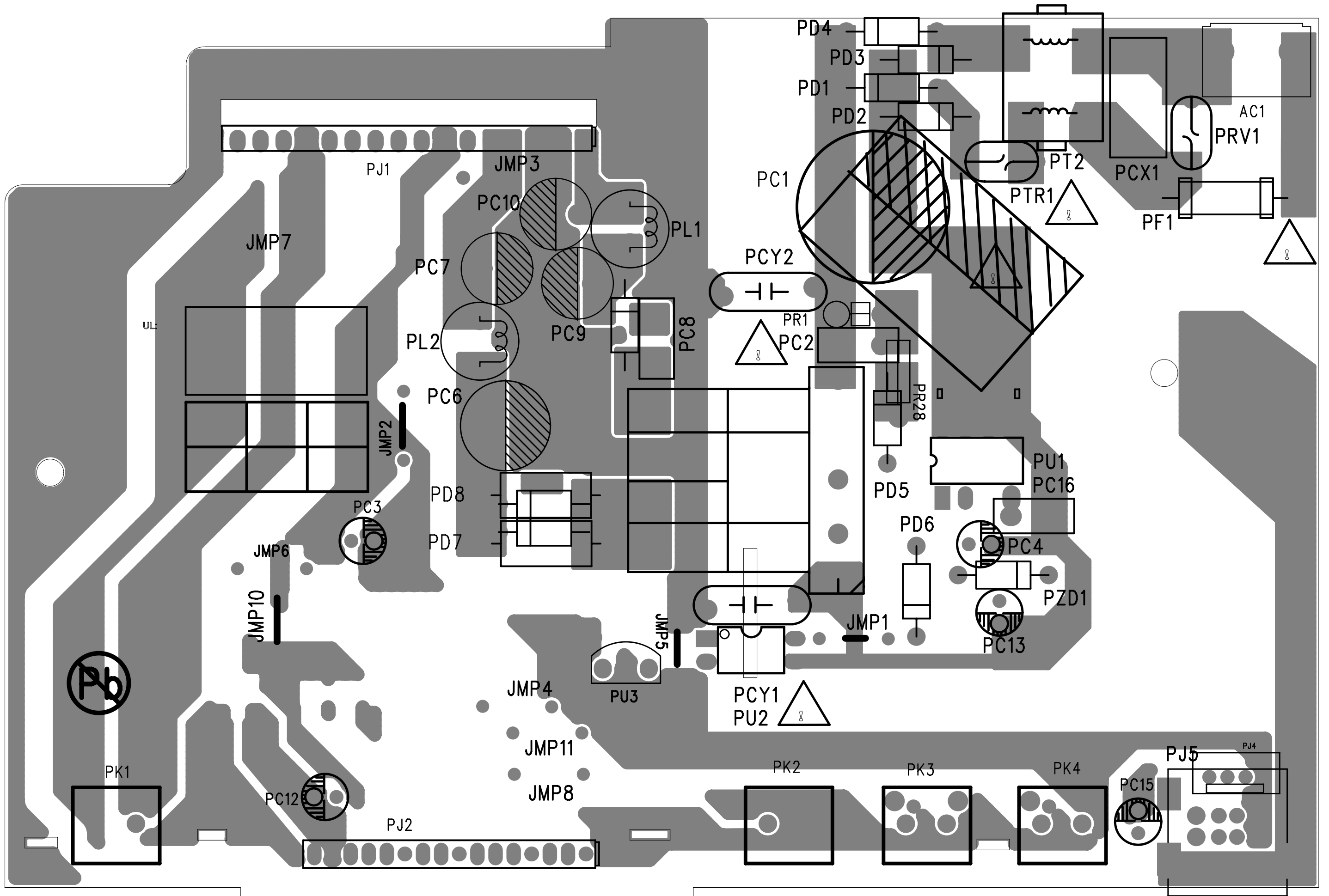

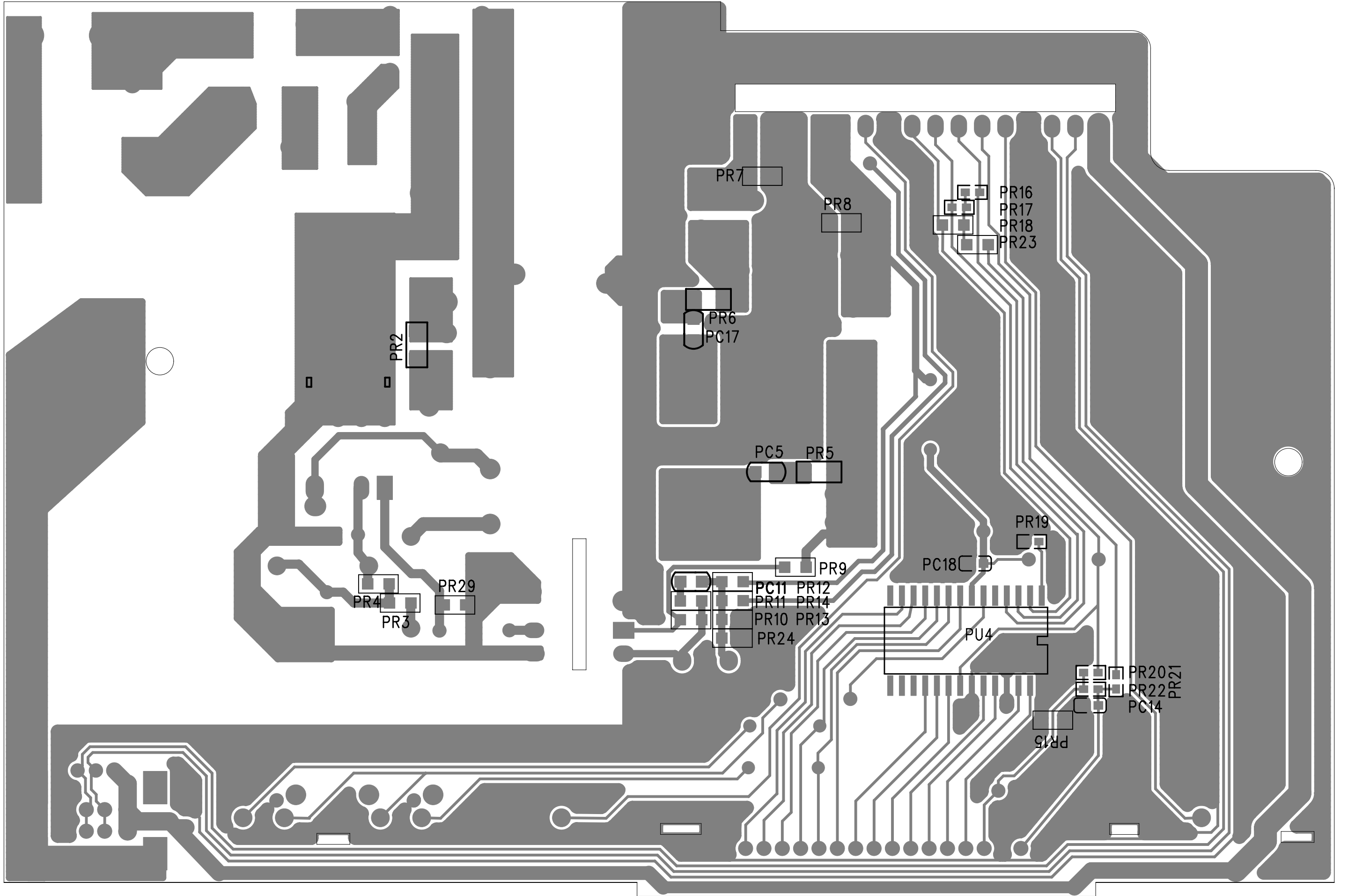

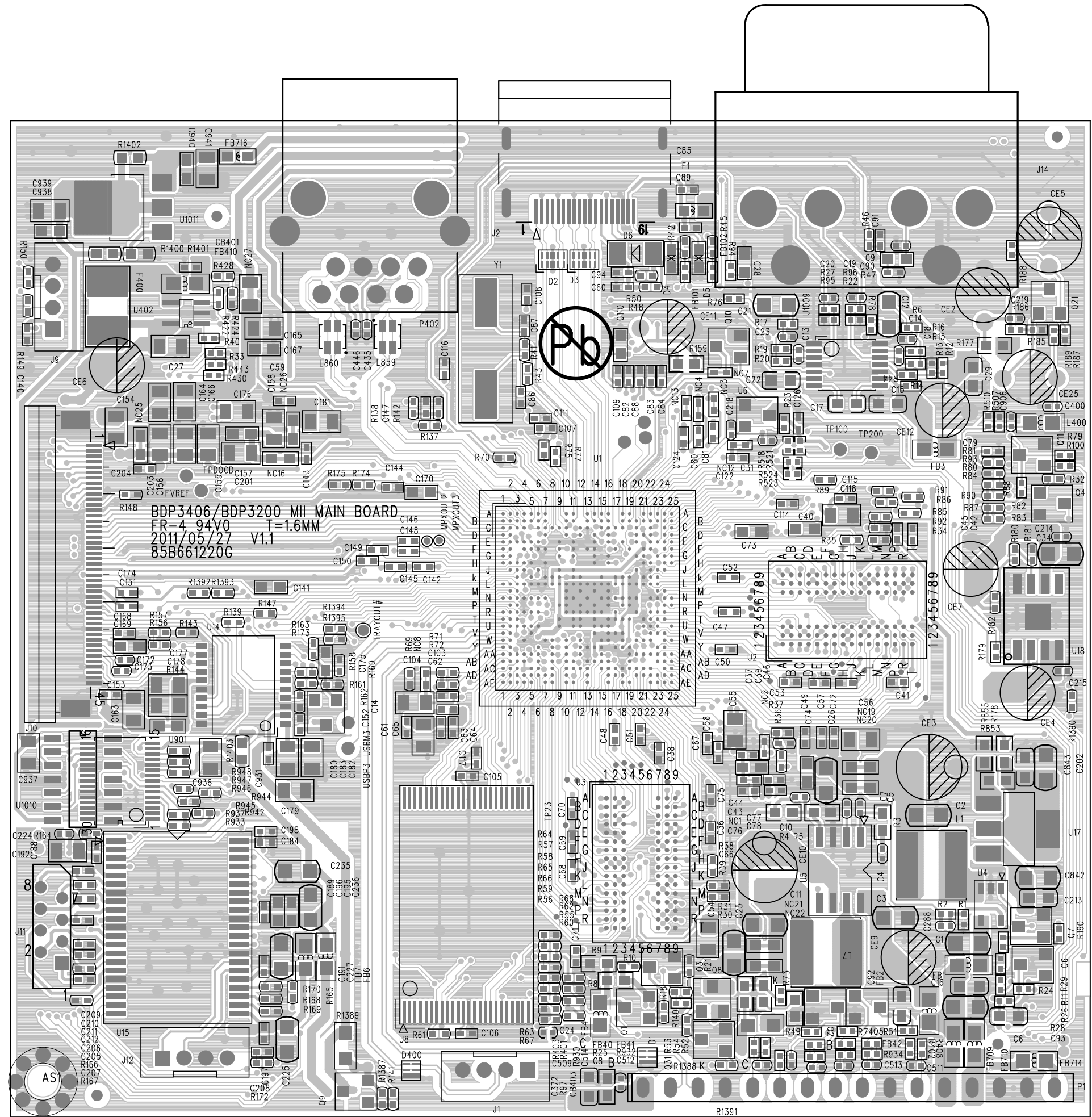

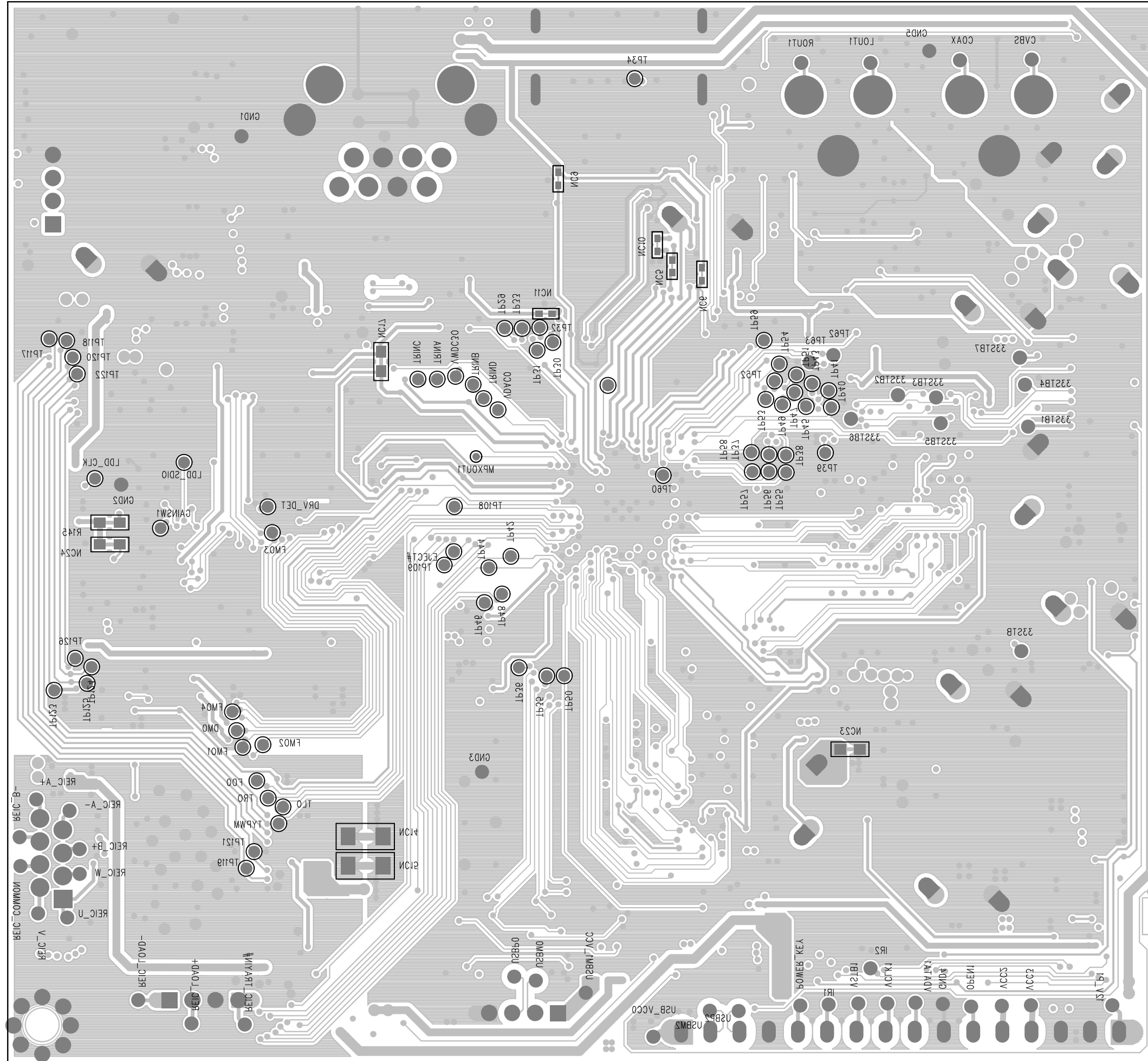

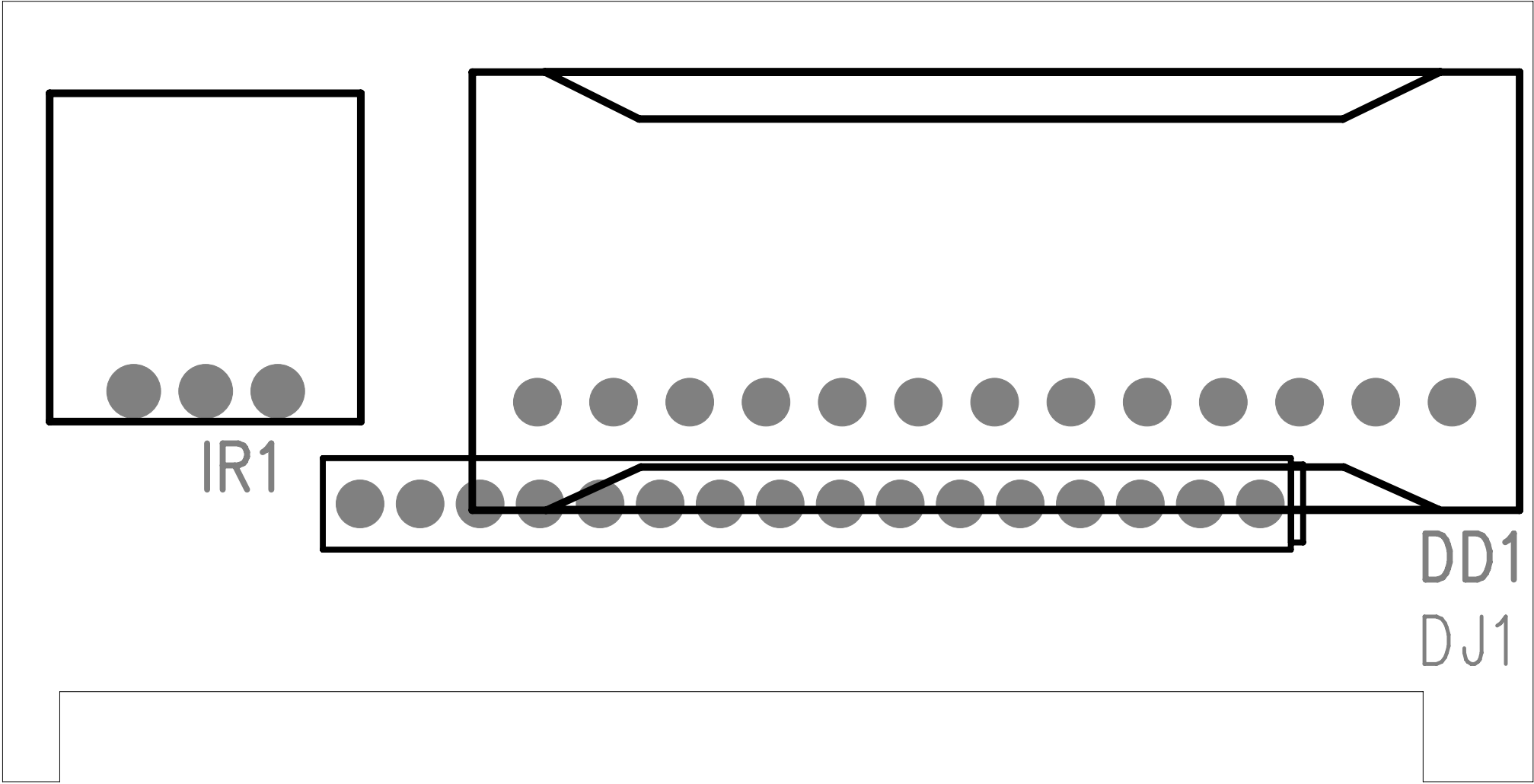

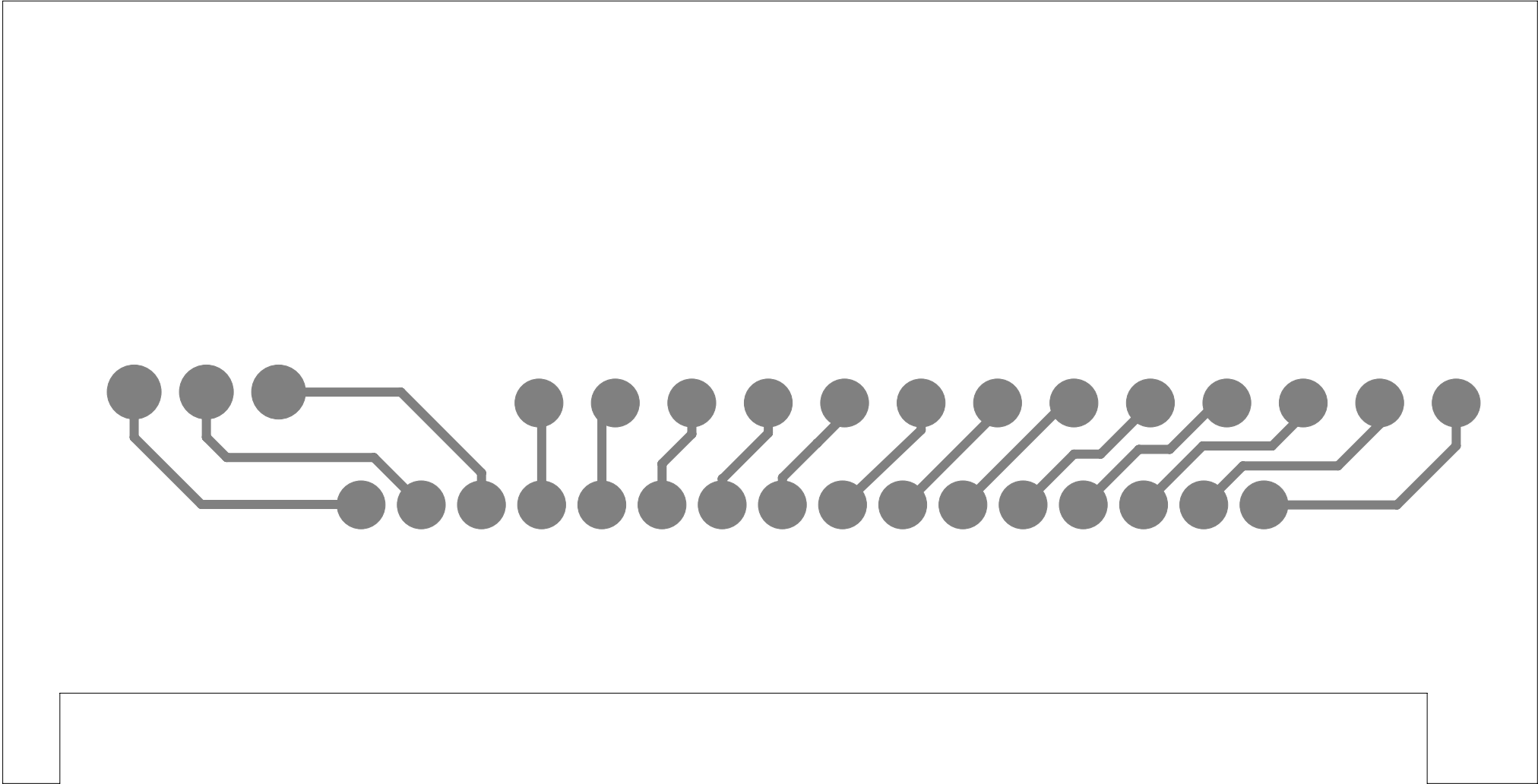

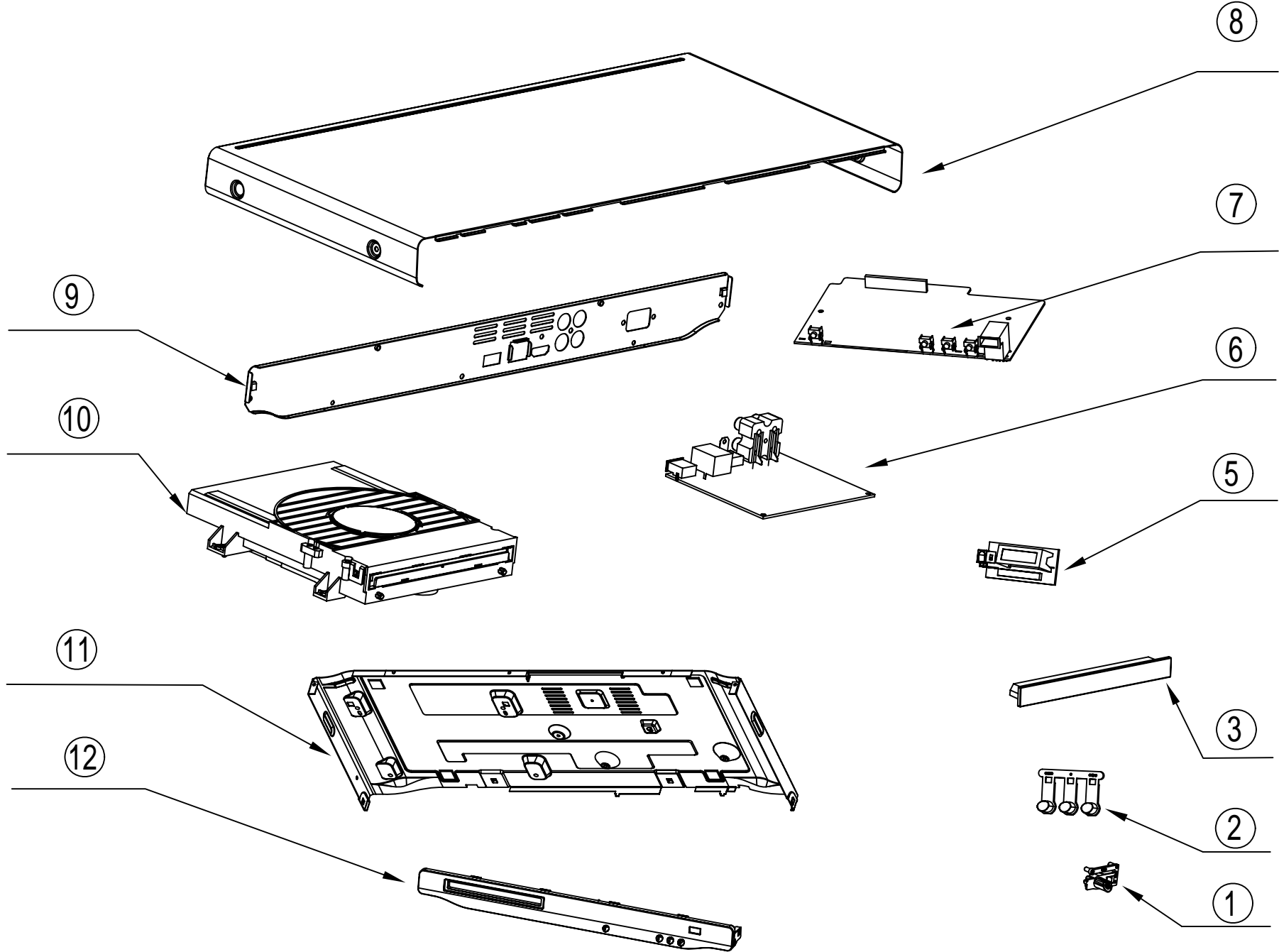

9.0 REVISION LIST

Version 1.0

- Initial release